



XS series PLC

User manual **【Hardware】**

Wuxi Xinje Electric Co., Ltd.

Data No. PS01 20240129EN 1.3

Basic description

- ◆ Thank you for purchasing the Xinje XS series programmable controller.
- ◆ This manual mainly introduces the hardware features of XS series programmable controllers.
- ◆ Before using the product, please read this manual carefully and conduct wiring on the premise of fully understanding the contents of the manual.
- ◆ Please deliver this manual to the end user.

Notes to users

- ◆ Only operators with certain electrical knowledge can conduct wiring and other operations on the product. If there is any unknown place, please consult our technical department.
- ◆ The examples listed in the manual and other technical data are only for users' understanding and reference, and do not guarantee certain actions.
- ◆ When using this product in combination with other products, please confirm whether it conforms to relevant specifications and principles.
- ◆ When using this product, please confirm whether it meets the requirements and is safe.
- ◆ Please set up backup and safety functions by yourself to avoid possible machine failure or loss caused by the failure of this product.

Statement of responsibility

- ◆ Although the contents of the manual have been carefully checked, errors are inevitable, and we cannot guarantee complete consistency.
- ◆ We will often check the contents of the manual and make corrections in subsequent versions. We welcome your valuable comments.
- ◆ The contents described in the manual are subject to change without notice.

Contact us

If you have any questions about the use of this product, please contact the agent and office who purchased the product, or you can directly contact the company.

- ◆ Tel: 400-885-0136
- ◆ Fax: 0510-85111290
- ◆ Address: No.816, Jianzhu West Road, Binhu District, Wuxi City, Jiangsu Province, China
- ◆ Post code: 214072
- ◆ Website: www.xinje.com

WUXI XINJE ELECTRIC CO., LTD. All rights reserved

This material and its contents shall not be copied, transmitted or used without explicit written permission. Violators shall be liable for the losses caused. All rights provided in the patent license and registration including utility modules or designs are reserved.

November 2021

Safety precautions

Before using this product, please read this part carefully and operate after fully understanding the use, safety, precautions, etc. of the product. Please correctly conduct product wiring under the premise of paying great attention to safety.

The problems that may arise during the use of the product are basically included in the safety precautions, which are indicated in two levels of attention and danger. For other unfinished matters, please follow the basic electrical operation procedures.



Attention

When used incorrectly, it may cause danger, moderate injury or minor injury, and property damage.



Danger

When it is used incorrectly, it may cause danger, cause personal injury or serious injury, and may cause serious property damage.

● Confirmation upon receiving the product



Attention

Do not install damaged controllers, controllers with missing parts, or controllers with unqualified models.
Danger of injury.

● Product system design



Danger

Please design a safety circuit outside the controller to ensure that the whole system can operate safely when the controller operates abnormally.
There is a risk of misoperation and failure.



Attention

Do not tie the control wiring and power wiring together. In principle, they should be separated by 10cm.
It may cause malfunction and product damage.

● Product installation



Danger

Before installing the controller, be sure to disconnect all external power supplies.
Danger of electric shock.



Attension

1. Please install and use this product under the environmental conditions specified in the general specifications of the manual.

Do not use in damp, high temperature, places with dust, smoke, conductive dust, corrosive gas, flammable gas, vibration and impact.

It may cause electric shock, fire, misoperation, product damage, etc.

2. Do not directly touch the conductive part of the product.

It may cause malfunction and fault.

3. Please use DIN46277 guide rail, M3 screw or Xinje XG-EB to fix the product and install it on a flat surface.

Incorrect installation may cause malfunction and product damage.

4. When processing the screw hole, please do not let the cutting powder and wire debris fall into the product cover.

It may cause malfunction and fault.

5. when connecting the expansion module with the expansion cable, please confirm that the connection is tight and the contact is good.

It may lead to poor communication and misoperation.

6. when connecting peripheral devices, expansion devices, batteries and other devices, be sure to cut off power for operation.

It may cause malfunction and fault.

● Product wiring



Danger

1. Before wiring the controller, be sure to disconnect all external power supplies.

Danger of electric shock.

2. Please correctly connect the DC power supply to the dedicated power terminal of the controller.

If the power supply is connected incorrectly, the controller may be burned.

3. Before the controller is powered on and operated, please cover the cover plate on the terminal block.

Danger of electric shock.



Attension

1. Do not use external 24V power supply to connect to 24V and 0V terminals of the controller or expansion module.

It may cause damage to the product.

2. Please use 2mm² wire to carry out the third kind of grounding for the grounding terminal of the controller and expansion equipment, and do not share the grounding with the strong current system.

It may cause failure, product damage, etc.

3. Do not make external wiring to the empty terminal.

It may cause malfunction and product damage.

4. When processing the screw hole, please do not let the cutting powder and wire debris fall into the product cover.

May cause malfunction, fault, etc.

5. When using wires to connect terminals, be sure to tighten them, and do not make conductive parts contact other wires or terminals.

It may cause malfunction and product damage.

● Operation and maintenance of products



Danger

1. Do not touch the terminal after the controller is powered on.

Danger of electric shock.

2. Do not connect or remove the terminal with electricity.

Danger of electric shock.

3. Please stop the program in the controller before changing it.

It may cause malfunction.



Attention

1. Do not disassemble or assemble this product without authorization.

It may cause damage to the product.

2. Please plug and unplug the connecting cable in case of power failure.

It may cause cable damage and malfunction.

3. Do not make external wiring to the empty terminal.

It may cause malfunction and product damage.

4. Please cut off the power before removing the expansion device, peripheral device and battery.

It may cause malfunction, fault, etc.

5. When the product is discarded, please treat it as industrial waste.

Catalog

SAFETY PRECAUTIONS	II
PREFACE	I
1. XS SERIES PLC OVERVIEW	1
1-1. PRODUCT FEATURES	1
1-1-1. XSDH series basic unit	1
1-1-2. XS3 series basic unit	2
1-1-3. XSLH series basic unit	4
1-1-4. XSA basic unit	6
1-1-5. XSDH series expansion modules	7
1-1-6. XS3 series expansion modules	8
1-1-7. XSLH series expansion modules	8
1-2. MODEL COMPOSITION AND MODEL TABLE	8
1-2-1. XSDH basic unit and models	8
1-2-2. XSDH expansion unit model composition and model table	9
1-2-3. XS3 model composition and model table of basic unit	11
1-2-4. XS3 expansion unit model composition and model table	12
1-2-5. XSLH basic unit model composition and model table	13
1-2-6. XSLH expansion unit model composition and model table	14
1-2-7. XSA model composition and model table of basic unit	16
1-3. PART INTRODUCTION	17
1-3-1. XSDH series structure composition	17
1-3-2. XS3 series structure composition	18
1-3-3. XSLH series structure composition	19
1-3-4. XSA series structure composition	20
2. MAIN BODY SPECIFICATION PARAMETERS	27
2-1. SPECIFICATION PARAMETERS	27
2-1-1. General specification	27
2-1-2. Performance specification	27
2-2. DIMENSION	28
2-2-1. XSDH series PLC dimension	28
2-2-2. XS3 series dimension	29
2-2-3. XSLH series PLC dimension	29
2-2-4. XSA series PLC dimension	30
2-3. TERMINAL ARRANGEMENT	32
2-3-1. XSDH series terminal arrangement	32
2-3-2. XS3 series terminal arrangement	32
2-3-3. XSLH series terminal arrangement	33
2-3-4. XSA series terminal arrangement	33
2-4. COMMUNICATION PORTS	34
3. SYSTEM COMPOSITION	36
3-1. SYSTEM COMPOSITION	36
3-2. PERIPHERALS	37
3-2-1. Programming software	37
3-2-2. HMI	37

3-2-3. <i>Power supply module</i>	38
3-2-4. <i>Terminal block and connection cable</i>	41
3-3. CONSTITUTION PRINCIPLE.....	43
3-4. PRODUCT INSTALLATION.....	44
3-4-1. <i>Installation location</i>	44
3-4-2. <i>Installation method</i>	44
3-4-4. <i>Installation environment</i>	47
4. POWER SUPPLY SPECIFICATION.....	48
4-1. POWER SUPPLY SPECIFICATION.....	48
4-2. AC POWER SUPPLY DC INPUT.....	49
5. INPUT SPECIFICATION AND WIRING.....	50
5-1. INPUT SPECIFICATION.....	50
5-1-1. <i>XSDH series input specification</i>	50
5-1-2. <i>XS3 series input specification</i>	51
5-1-3. <i>XSLH series input specification</i>	53
5-1-4. <i>XSA series input specification</i>	56
5-2. DC INPUT SIGNAL.....	59
5-3. HIGH SPEED COUNT INPUT.....	60
5-3-1. <i>Count mode</i>	60
5-3-2. <i>High-speed counter range</i>	61
5-3-3. <i>High-speed counter input wiring</i>	61
5-3-4. <i>Input terminal assignment</i>	62
6. OUTPUT SPECIFICATION AND WIRING METHOD.....	66
6-1. OUTPUT SPECIFICATION.....	66
6-2. TRANSISTOR OUTPUT.....	67
7. BIOS SETTING.....	69
7-1. BIOS EXPLANATION.....	69
7-1-1. <i>CMOS setup</i>	69
7-1-2. <i>Function keys and auxiliary instructions</i>	69
7-2. MAIN MENU.....	70
7-3. MAIN(STANDARD CMOS SETTING).....	71
7-4. ADVANCED BIOS FUNCTION.....	72
7-5. CHIPSET PERFORMANCE SETTING.....	73
7-6. SECURITY (ADMINISTRATOR/USER PASSWORD).....	74
7-7. BOOT SETTING.....	75
7-8. SAVE & EXIT.....	76
7-9. SET COM PORT MODE.....	77
8. OPERATION, COMMISSIONING AND MAINTENANCE.....	79
8-1. OPERATION AND COMMISSIONING.....	79
8-2. ROUTINE MAINTENANCE.....	80
APPENDIX.....	81
APPENDIX 1. PLC FUNCTION CONFIGURATION LIST.....	81
APPENDIX 2. Q&A.....	81

Preface

The following describes the content of this manual, the scope of application of this manual, the conventions in this manual, the introduction of related manuals, and the way to obtain manual materials.

Manual application range

This manual is the hardware manual of XS series programmable controller products. The manual covers the following product information:

1. XSDH series PLC

Type	Series	Product model
Basic unit	XSDH series	XSDH-60A32-E, XSDH-60PA32-E
Expansion module	I/O expansion	XD-E8X, XD-E16X, XD-E32X
		XD-E8Y, XD-E16Y, XD-E32Y
		XD-E8X8Y, XD-E16X16Y
	AD/DA expansion	AD type: XD-E4AD, XD-E8AD, XD-E8AD-A, XD-E8AD-V, XD-E12AD-V
		DA type: XD-E2DA, XD-E4DA
		AD/DA type: XD-E4AD2DA
	Temperature expansion	XD-E4PT3-P, XD-E6PT-P, XD-E2TC-P, XD-E6TC-P, XD-E6TC-P-H
	Mixed expansion	XD-E3AD4PT2DA, XD-E2AD2PT2DA
	Weighing extension	XD-E1WT-C, XD-E2WT-C, XD-E4WT-C XD-E1WT-D, XD-E2WT-D, XD-E4WT-D
SSI encoder expansion	XD-E4SSI	
Macro measurement extension	XD-E2GRP	

2.XS3 series PLC

Type	Series	Product model
Basic unit	XS3 series	XS3-26T4
Expansion module	I/O expansion	XG-E16X, XG-E32X, XG-E64X
		XG-E16YR, XG-E16YT, XG-E32YT, XG-E64YT
		XG-E8X8YR, XG-E8X8YT, XG-E16X16YT
	AD/DA expansion	AD type: XG-E8AD-A-S, XG-E8AD-V-S
		DA type: XG-E4DA-S AD/DA type: XG-E4AD2DA
Temperature measurement	XG-E8PT3-P, XG-E8TC-P	
Accessories	Power supply module	XG-P75-E
	Bus connector	XG-EUC-1, XG-EUCT-1
	Mounting rail	XG-EB-170, XG-EB-260, XG-EB-385, XG-EB-590, XG-EB-880, XG-EB-1500
	External terminal block	JT-G26

Type	Series	Product model
	Connecting cable for external terminal block	JC-G26-NN05 (0.5m), JC-G26-NN10 (1.0m), JC-G26-NN15 (1.5m)
	Elbow XVP cable	JC-EL-25 (2.5m), JC-EL-50 (5.0m), JC-EL-100 (10m)
	USB convertor	USB-COM
	USB download cable	JC-UA-15

3.XSLH series PLC

Type	Series	Product model
Basic unit	XSLH series	XSLH-30A32
Expansion module	I/O expansion	XL-E16X, XL-E16PX, XL-E32X, XL-E32PX
		XL-E16YR, XL-E16YT, XL-E16YT-A, XL-E32YT
		XL-E8X8YR, XL-E8PX8YR, XL-E8X8YT, XL-E8PX8YT
		XL-E16X16YT, XL-E16PX16YT, XL-E16X16YT-A, XL-E16PX16YT-A
	AD/DA expansion	AD type: XL-E4AD, XL-E8AD-A, XL-E8AD-V, XL-E8AD-A-S, XL-E8AD-V-S DA type: XL-E2DA, XL-E4DA AD/DA type: XL-E4AD2DA
Temperature measurement	XL-E4TC-P, XL-E4PT3-P	
Pressure measurement	XL-E1WT-D, XL-E2WT-D, XL-E4WT-D	

Conventions in the manual

Due to space limitations, some abbreviations may be used in the manual to replace the original names. These names that may be involved are listed in the following table for comparison.

Abbreviation	Explanation
XS series PLC	XS series programmable controller
Basic unit or main body	XS series programmable controller basic unit
Expansion module	XS series programmable controller expansion modules
I/O expansion	XS series programmable controller I/O expansion modules
Analog expansion	XS series programmable controller analog expansion modules
Peripherals	Programming software, HMI, network modules
Programming software	Codesys programming software
HMI	TG, OP series HMI products
TG series	TG series HMI
OP series	OP series operate panel

Related manuals

This manual only covers the hardware of XS series PLC. For other applications, please refer to the relevant manuals. Relevant manuals are listed below for users' reference.

Manual	Introduction	Note
Software manual		
XS series PLC user manual [software]	This paper introduces the use methods and skills of Codesys programming tool software	PDF
Instruction manual		
XS series PLC user manual [motion control]	Introduce the usage of XS series PLC advanced motion control instructions	PDF
Expansion module manual		
XD series PLC expansion module user manual	Introduce the specification parameters and terminal wiring of XSDH series expansion module	PDF
XG series PLC expansion module user manual	Introduce the specification parameters and terminal wiring of XS3 series expansion module	PDF
XL series PLC expansion module user manual	Introduce the specification parameters and terminal wiring of XSLH series expansion module	PDF

1. XS series PLC overview

1-1. Product features

1-1-1. XSDH series basic unit

(1) Model explanation

The basic unit of XSDH series medium-sized PLC currently has one product model.

- I/O points 60 points
- Output type Transistor
- Input type NPN
- Power supply AC220V

Series	Description
XSDH	Includes 60 points specifications. Based on Codesys programming platform, it supports PLCopen programming specification, with larger internal resource space. The main processor has a dominant frequency of 1GHz, supports Ethernet communication, EtherCAT bus function, EtherCAT remote IO, 32-channel electronic cam, online download, and supports 16 expansion modules, which can meet most user needs.

(2) Powerful function

XSDH series PLC has substantial basic functions and a variety of special functions.

Enriching basic functions

- ◆ **High speed operation**
The main processor of XSDH series PLC has a main frequency of 1GHz, which can meet the requirements of high-speed operation.
- ◆ **Rich expansion modules**
XSDH series PLC can support 16 XD series expansion modules.
- ◆ **Multi-communication ports**
The basic unit has four communication ports, which support RS232, RS485. It supports LAN port and EtherCAT communication.
- ◆ **Large memory**
XSDH series PLC has 32M user program capacity and 32M data capacity.
- ◆ **6 kinds of programming method**
XSDH series PLC support ST, SFC, FBD, CFC, LD and IL.
- ◆ **Rich instruction set**
XSDH series PLC supports PLCopen programming specification, and can reference many standard function libraries to develop proprietary function blocks and instruction libraries.
- ◆ **Real-time clock**
XSDH series PLC has built-in clock to control the time.
- ◆ **Easy to install**
XSDH series PLC is easy to install. It can be installed directly on the guide rail or fixed with M3 screws.

Enhanced special functions

◆ **EtherCAT bus**

XSDH series PLC supports EtherCAT bus communication, supports up to 32 stations (32-axis motors can be controlled synchronously), and supports communication with EEPROM slave stations, such as Xinje-DS5C, Inovance servo, Panasonic EtherCAT servo, Kollmorgen servo, etc.

XSDH series PLC supports 32-channel electronic cam function and connection of EtherCAT remote IO module through EtherCAT bus. Please refer to *XS Series PLCopen Instruction Manual* for specific use.

◆ **Ethernet communication**

XSDH series PLC supports Ethernet communication, which can realize faster and more stable program / data download and better real-time performance. It supports PLC access to the Internet, and realizes remote search, online monitoring, uploading and downloading of PLC program.

◆ **High speed counter, up to 200KHz**

The basic unit of XSDH series PLC is equipped with 4-channel, 2-phase high-speed counter and high-speed counting comparator, which can count in two modes: single-phase and AB phase. The single-phase frequency can reach 200kHz and AB phase can reach 100kHz.

◆ **Interrupt function**

XSDH series PLC has 14-channel external interrupt function.

◆ **Online download**

XSDH series PLC supports online download function to truly realize PLC non-stop operation.

◆ **Simulation**

In the case of no hardware, it supports simulation, which is helpful for programming.

◆ **Dial switch**

It is used to initialize IP, power on without loading the user program, start normally, without special treatment, load the user program, update the product.

(3) Easy programming

XSDH series PLC is programmed in Codesys programming software. Please refer to *XS Series PLCopen Manual [Software]* for specific use.

1-1-2. XS3 series basic unit

(1) Model explanation

At present, the basic unit of XS3 series medium-sized PLC has one product model.

- I/O points 26 points
- Output type Transistor
- Input type NPN
- Power supply DC24V

Series		Description
XS3	XS3-26T4	Includes 26-point specifications. The basic Codesys programming platform supports PLCopen programming specification, with larger internal resource space. The main processor frequency is 800MHz, supports Ethernet communication, EtherCAT bus function, EtherCAT remote IO, 32-channel electronic cam, online download, and supports 16 expansion modules, which can meet most of the user's needs.

XS3 series PLC has substantial basic functions and a variety of special functions.

Enriching basic functions

- ◆ **High speed operation**
The main processor of XS3 series PLC has a main frequency of 800MHz, which can meet the requirements of high-speed operation.
- ◆ **Rich expansion modules**
XS3 series PLC can support 16 XG series expansion modules.
- ◆ **Multi-communication ports**
The basic unit has five communication ports, which support RS232, RS485. It supports LAN port and EtherCAT communication.
- ◆ **Large memory**
The XS3 series PLC has a data capacity of 32MB, program capacity of 32MB, and 6M power outage retention capacity.
- ◆ **6 kinds of programming method**
XS3 series PLC support ST, SFC, FBD, CFC, LD and IL.
- ◆ **Rich instruction set**
XS3 series PLC supports PLCopen programming specification, and can reference many standard function libraries to develop proprietary function blocks and instruction libraries.
- ◆ **Real-time clock**
XS3 series PLC has built-in clock to control the time.
- ◆ **Easy to install**
XS3 series PLC is easy to install. It can be installed directly on the guide rail.

Enhanced special functions

- ◆ **EtherCAT bus**
XS3 series PLC supports EtherCAT bus communication, supports up to 32 stations (32-axis motors can be controlled synchronously), and supports communication with EEPROM slave stations, such as Xinje-DS5C, Inovance servo, Panasonic EtherCAT servo, Kollmorgen servo, etc.
XS3 series PLC supports 32-channel electronic cam function and connection of EtherCAT remote IO module through EtherCAT bus.
- ◆ **Ethernet communication**
XS3 series PLC supports Ethernet communication, which can realize faster and more stable program / data download and better real-time performance. It supports PLC access to the Internet, and realizes remote search, online monitoring, uploading and downloading of PLC program.
- ◆ **High speed counter, up to 200KHz**
The basic unit of XS3 series PLC is equipped with 4-channel, 2-phase high-speed counter and high-speed counting comparator, which can count in two modes: single-phase and AB phase. The frequency can reach 200kHz.
- ◆ **Interrupt function**
XS3 series PLC has 6-channel external interrupt function.

(2) Easy programming

XS3 series PLC is programmed in Codesys programming software. Please refer to XS series PLC user manual [software] for specific use.

1-1-3. XSLH series basic unit

(1) Model explanation

At present, the basic unit of XSLH series small PLC currently has one product model.

- I/O points 24, 30 points
- Output type Transistor
- Input type NPN, PNP, differential
- Power supply DC24V

Series	Description
XSLH	Include 24, 30 points specifications. Based on CODESYS programming platform, it supports PLCopen programming specification, has larger internal resource space, the main frequency of the main processor is 1GHz, supports Ethernet communication, CANopen communication, EtherCAT bus function, CANopen bus function, EtherCAT remote IO, 8/16/32 channels electronic cam, online download, and supports 16 expansion modules, which can meet most user needs.

(2) Powerful function

XSLH series PLC has substantial basic functions and a variety of special functions.

Enriching basic function

- ◆ **High speed operation**
The main frequency of the main processor of the XSLH series PLC is up to 1GHz, which can meet the requirements of high-speed operation.
- ◆ **Rich expansion modules**
XSLH series PLC can support 16 XL series expansion modules of different types and models
- ◆ **Multi-communication ports**
The basic unit has 6 communication ports, supporting RS232 and RS485 ports to connect multiple external devices, supporting LAN port access to the LAN, and supporting EtherCAT and CANopen communication.
- ◆ **Large memory**
XSLH series PLC has 32M user program capacity, 32M data capacity and 6M power-off retention capacity.
- ◆ **6 kinds of programming method**
XSLH series PLC support ST, SFC, FBD, CFC, LD and IL.
- ◆ **Rich instruction set**
XSLH series PLC supports PLCopen programming specification, can reference many standard function libraries, and develop proprietary function blocks and instruction libraries.
- ◆ **Real time clock**
XSLH series PLC built-in clock for time control
- ◆ **Easy to install**
XSLH series PLC is easy to install, which can be directly installed by guide rail or fixed with M3 screws.

Enhanced special functions

- ◆ **EtherCAT bus**

XSLH series PLC supports EtherCAT bus communication, supports up to 32 stations (32-axis motors can be controlled synchronously), and supports communication with EEPROM slave stations, such as Xinje-DS5C, Inovance servo, Panasonic EtherCAT servo, Kollmorgen servo, etc.

XSLH series PLC supports 32-channel electronic cam function and connection of EtherCAT remote IO module through EtherCAT bus.

Please refer to *XS Series PLCopen Instruction Manual* for specific use.

- ◆ **CANopen bus**

The physical layer of CAN bus is very stable. The data link layer is reliable, flexible, highly compatible, and highly interoperable. It supports a maximum of 16 stations (16-axis motors can be controlled synchronously).

- ◆ **Ethernet communication**

XSLH series PLC supports Ethernet communication, which can realize faster and more stable program / data download and better real-time performance. It supports PLC access to the Internet, and realizes remote search, online monitoring, uploading and downloading of PLC program.

- ◆ **High speed pulse counter, up to 200KHz**

The basic unit of XSLH series PLC supports 2-channel OC signal and 2-channel differential signal input, and can count in single-phase and AB phase modes. The differential model can be up to 1MHz, the single-phase can be up to 80KHz, and the AB phase can be up to 50KHz.

- ◆ **Interrupt function**

XSLH series PLC has 10 channels external interrupt function.

- ◆ **Online downloading**

XSLH PLC supports online download function, which truly realizes PLC non-stop operation.

- ◆ **Simulation**

It supports simulation without connecting hardware, which is helpful for programming.

- ◆ **Dial switch**

Used to initialize IP, power on without loading user program, normal startup, no special processing, loading user program, and updating the product.

(3) Easy programming

XSLH series PLC is programmed in Codesys programming software. Please refer to *XS Series PLCopen Software Manual* for specific use.

1-1-4. XSA basic unit

(1) Model explanation

The basic unit of XSA.

- I/O points 32 points
- Output type Transistor
- Input type Bipolar
- Power supply DC24V

Series	Description
XSA300	Includes 32 points specifications. Based on the CODESYS programming platform, it supports PLCopen programming specifications and has a larger internal resource space. The main processor J3455 has a frequency of 1.5 GHz and supports Ethernet communication and EtherCAT bus functions. It supports 128 EtherCAT communication nodes, 64 EtherCAT axes, and online downloading, which can meet most of the user's usage needs.
XSA500	Includes 32 points specifications. Based on the CODESYS programming platform, it supports PLCopen programming specifications and has a larger internal resource space. The XSA520 main processor I3-1115G4 has a main frequency of 3GHz, the XSA530 main processor I5-1135G7 has a main frequency of 2.4GHz, and the XSA550 main processor I7-1165G7 has a main frequency of 2.8GHz. It supports Ethernet communication, EtherCAT bus function, and 256 EtherCAT communication nodes (EtherCAT axes: 64 for XSA520, 128 for XSA530, and 256 for XSA550). It can be downloaded online, and meet most of the user's needs.

(2) Powerful function

XSA series PLC has substantial basic functions and a variety of special functions.

Enriching basic functions

- ◆ **High speed operation**
The main processor of XSA series PLC has a maximum main frequency of up to 3GHz, which can meet the requirements of high-speed operation.
- ◆ **Rich expansion modules**
Based on EtherCAT bus IO expansion, it can be connected to DI/DO expansion and analog data acquisition expansion
- ◆ **Multi-communication ports**
The basic unit has six communication ports, which support RS232, RS485. It supports LAN port and EtherCAT communication.
- ◆ **Large memory**
XSA series PLC has 128M user program capacity, 128M data capacity and 6M power failure holding capacity.
- ◆ **6 kinds of programming method**
XSA series PLC support ST, SFC, FBD, CFC, LD and IL.
- ◆ **Rich instruction set**
XSA series PLC supports PLCopen programming specification, and can reference many standard

function libraries to develop proprietary function blocks and instruction libraries.

- ◆ **Real-time clock**

XSA PLC has built-in clock to control the time.

- ◆ **Easy to install**

XSA series PLC is easy to install. It can be installed directly on the guide rail or fixed with M3 screws.

Enhanced special functions

- ◆ **EtherCAT bus**

XSA series supports EtherCAT bus communication, supports up to 256 stations (256-axis motors can be controlled synchronously), and supports communication with EEPROM slave stations, such as Xinje-DS5C, Inovance servo, Panasonic EtherCAT servo, Kollmorgen servo, etc.

Please refer to *XS Series PLCopen Instruction Manual* for specific use.

- ◆ **Ethernet communication**

XSA series supports Ethernet communication, which can realize faster and more stable program / data download and better real-time performance. It supports PLC access to the Internet, and realizes remote search, online monitoring, uploading and downloading of PLC program.

- ◆ **High speed counter, encoder differential input up to 1MHz**

The basic unit of XSA series industrial control computer is equipped with 4-channel, 2-phase high-speed counter and high-speed counting comparator, which can count in single-phase and AB phase modes. The encoder differential type frequency can reach 1MHz, single-phase frequency can reach 200KHz, and AB phase can reach 100KHz.

- ◆ **Interrupt function**

XSA series has 16-channel external interrupt function.

- ◆ **Online download**

XSA series supports online download function to truly realize PLC non-stop operation.

- ◆ **Simulation**

In the case of no hardware, it supports simulation, which is helpful for programming.

(3) Easy programming

XSA series PLC is programmed in XS STUDIO programming software. Please refer to *XS Series PLCopen Software Manual* for specific use.

1-1-5. XSDH series expansion modules

In order to better meet the field control requirements, XSDH series PLC can be extended with 16 XD expansion modules.

- Rich types: including input and output expansion module, analog module and temperature control module.
- I/O expansion module
Input 8~32 points. Output points: 8~32. Output type: transistor, relay. Power supply: DC24V.
- Analog module
Type: AD, DA, AD/DA. Channels: AD 4~8, DA 2~4. Power supply: DC24V.
- Temperature control module
Type: PT100, thermocouple. Channels: 8. PID control: built in, transistor. Power supply: DC24V.

1-1-6. XS3 series expansion modules

In order to better meet the field control requirements, XS3 series PLC can be extended with 16 XD expansion modules.

- Rich types: including input and output expansion module, analog module and temperature control module.
- I/O expansion module
Input 8~32 points. Output points: 8~32. Output type: transistor, relay. Power supply: DC24V.
- Analog module
Type: AD, DA, AD/DA. Channels: AD 4~8, DA 2~4. Power supply: DC24V.
- Temperature control module
Type: PT100, thermocouple. Channels: 8. PID control: built in, transistor. Power supply: DC24V.

1-1-7. XSLH series expansion modules

In order to better meet the field control requirements, XSLH series PLC can be extended with 16 XL expansion modules.

- Rich types: including input and output expansion module, analog module and temperature control module.
- I/O expansion module
Input 8~32 points. Output points: 8~32. Output type: transistor, relay. Power supply: DC24V.
- Analog module
Type: AD, DA, AD/DA. Channels: AD 4~8, DA 2~4. Power supply: DC24V.
- Temperature control module
Type: PT100, thermocouple. Channels: 8. PID control: built in, transistor. Power supply: DC24V.

1-2. Model composition and model table

1-2-1. XSDH basic unit and models

(1) Model composition of basic unit

The basic unit model composition of XSDH series PLC is generally as follows:

$\frac{X}{①} \frac{S}{②} \frac{D}{③} \frac{H}{④} - \frac{60}{⑤} \frac{A}{⑥} \frac{32}{⑦} - \frac{E}{⑧}$

① Product type	X: Controller
② Use platform	S: CODESYS
③ Appearance structure	D: Same to XDH
④ Performance level	H: Motion control enhanced type
⑤ I/O points	60: 36 inputs/24 outputs
⑥ Connection symbol	A: Axis
⑦ Control axis number	32: can control 32 EtherCAT axes
⑧ Power supply	E: AC220V

(2) Basic unit model list

◆ XSDH model list

Model							Input points (DC24V)	Output points (R, T)
AC power supply			DC power supply					
	Relay output	Transistor output	Relay&transistor mixed output	Relay output	Transistor output	Relay&transistor mixed output		
NPN model	-	XSDH-60A32-E	-	-	-	-	36	24
PNP Model	-	XSDH-60PA32-E	-	-	-	-	36	24

1-2-2. XSDH expansion unit model composition and model table

(1) I/O expansion model

I/O model composition of the expansion module is as follows:

$\underline{\text{XD}} - \underline{\text{E}} \quad \underline{\bigcirc} \quad \underline{\square} \quad \underline{\bigcirc} \quad \underline{\square} - \underline{\square}$
 ① ② ③ ④ ⑤ ⑥ ⑦

- ①: Series name XD
- ②: Expansion module E
- ③: Input points 8/16/32
- ④: Special for input NPN input: X
PNP input: PX
- ⑤: Output points 8/16/32
- ⑥: Output mode YR: relay output
YT: transistor output
- ⑦: Power supply E: AC220V
C: DC24V

◆ I/O expansion module model list

	Model			I/O points	Input points (DC24V)	Output points (R, T)
	Input	Output				
		Relay output	Transistor output			
NPN type	XD-E8X	-	-	8	8	-
	-	XD-E8YR	XD-E8YT	8	-	8
	-	XD-E8X8YR	XD-E8X8YT	16	8	8
	XD-E16X	-	-	16	16	-
	-	XD-E16YR	XD-E16YT	16	-	16
	-	XD-E16X16YR-E	XD-E16X16YT-E	32	16	16
	-	XD-E16X16YR-C	XD-E16X16YT-C	32	16	16
	XD-E32X-E	-	-	32	32	-
	XD-E32X-C	-	-	32	32	-

	-	XD-E32YR-E	XD-E32YT-E	32	-	32
	-	XD-E32YR-C	XD-E32YT-C	32	-	32

(2) Analog and temperature control modules

The model composition of analog quantity and temperature expansion module is as follows:

$$\text{XD} - \text{E} \frac{4\text{AD}}{\textcircled{1}} \frac{2\text{DA}}{\textcircled{2}} \frac{6\text{PT}}{\textcircled{3}} \frac{6\text{TC}}{\textcircled{4}} \frac{1\text{WT}}{\textcircled{5}} \frac{4\text{SSI}}{\textcircled{6}} - \frac{\text{P}}{\textcircled{7}} - \frac{\text{H}}{\textcircled{8}} \frac{\text{H}}{\textcircled{9}}$$

- ①: Expansion E: Expansion module
- ②: Analog input 4AD: 4 channels analog input
 8AD: 8 channels analog input
 12AD: 12 channels analog input
- ③: Analog output 2DA: 2 channels analog output
 4DA: 4 channels analog output
- ④: Temperature measurement 6PT: 6 channels platinum thermistor input
 4PT3: 4 channels platinum thermistor input (3-wire)
- ⑤: Temperature measurement 6TC: 6 channels thermocouple input
- ⑥: Pressure measurement 1WT: 1 channel pressure measurement
 2WT: 2 channels pressure measurement
 4WT: 4 channels pressure measurement
- ⑦: Encoder detection 4SSI: 4 channels encoder detection
- ⑧: Model difference P: PID control
 A: Hardware is new version (only for WT module)
 Input is current (only for 8AD module)
 B: analog voltage output -5V~5V or -10V~10V (only for 4AD2DA module)
 Hardware version difference (only for WT module)
 C: Hardware version difference (only for WT module)
 D: Hardware version difference (only for WT module)
 V: Input is voltage type (for 8AD, 12AD module)
 None: standard
- ⑨: Isolation H: Each channel is isolated from each other (only for 6TC-P-H module)

◆ Analog, temperature expansion module list

Model	Description	
Analog input	XD-E4AD	4 channels analog input
	XD-E8AD	8 channels analog input, 4 channels voltage, 4 channels current
	XD-E8AD-A	8 channels analog input, current type
	XD-E8AD-V	8 channels analog input, voltage type
	XD-E12AD-V	12 channels analog input, voltage type
Analog I/O	XD-E4AD2DA	4 channels analog input, 2 channels analog output
	XD-E4AD2DA-B	4 channels analog input, 2 channels analog voltage output
Analog output	XD-E2DA	2 channels analog output

Model		Description
	XD-E4DA	4 channels analog output
Temperature measurement	XD-E6PT-P	6 channels PT100 input, built-in PID control
	XD-E4PT3-P	4 channels PT100 input, built-in PID control
	XD-E6TC-P	6 channels K type thermocouple input, built-in PID control
	XD-E6TC-P-H	6 channels K type thermocouple input, built-in PID control, each channel is isolated from each other
	XD-E2TC-P	2 channels K type thermocouple input, built-in PID control
Pressure measurement	XD-E1WT-A	1 channel pressure measurement, -39.06mV~39.06mV
	XD-E2WT-A	2 channels pressure measurement, -39.06mV~39.06mV
	XD-E4WT-A	4 channels pressure measurement, -39.06mV~39.06mV
	XD-E2WT-B	2 channels pressure measurement, 0~10mV
	XD-E1WT-C	1 channel pressure measurement, 0~10mV, 20 bits conversion accuracy
	XD-E2WT-C	2 channels pressure measurement, 0~10mV, 20 bits conversion accuracy
	XD-E4WT-C	4 channels pressure measurement, 0~10mV, 20 bits conversion accuracy
	XD-E1WT-D	1 channel pressure measurement, 0~10mV, 22 bits conversion accuracy
	XD-E2WT-D	2 channels pressure measurement, 0~10mV, 22 bits conversion accuracy
	XD-E4WT-D	4 channels pressure measurement, 0~10mV, 22 bits conversion accuracy

1-2-3. XS3 model composition and model table of basic unit

(1) Model composition of basic unit

XS3 series PLC basic unit model composition is generally as follows:

$$\frac{\text{X}}{\text{①}} \frac{\text{S}}{\text{②}} \frac{\text{3}}{\text{③}} - \frac{\text{26}}{\text{④}} \frac{\text{T}}{\text{⑤}} \frac{\text{4}}{\text{⑥}}$$

- | | |
|------------------------|--|
| ① Product type | X: Controller |
| ② Use platform | S: CODESYS |
| ③ Appearance structure | 3: 3 series |
| ④ I/O points | 26: 18 inputs/8 outputs |
| ⑤ Transistor output | T: transistor output |
| ⑥ Pulse channel | 4: 4 channels pulse output (currently not supported) |

(2) Basic unit model list

◆ XS3 series model list

Model							Input points (DC24V)	Output points (R, T)
AC power supply			DC power supply					
	Relay output	Transistor output	Relay&transistor mixed output	Relay output	Transistor output	Relay&transistor mixed output		
NPN type	-	-	-	-	XS3-26T4	-	18	8

6: Analog type A: current type
 V: voltage type

◆ Analog, temperature expansion model list

Model		Description
Analog I/O	XG-E8AD-A	8 channels analog input, current type
	XG-E8AD-V	8 channels analog input, voltage type
	XG-E4AD2DA	4 channels analog input, 2 channels analog output
	XG-E4DA	4 channels analog output
Temperature measurement	XG-E8PT3-P	8 channels PT100 temperature measurement, built-in PID control
	XG-E8TC-P	8 channels thermocouple temperature measurement, built-in PID control

1-2-5. XSLH basic unit model composition and model table

(1) Model composition of basic unit

XSLH series PLC basic unit model composition is generally as follows:

X S L H – 30 A 32
 ① ② ③ ④ ⑤ ⑥ ⑦

- | | | |
|---|----------------------|--|
| ① | Product type | X: Controller |
| ② | Use platform | S: CODESYS |
| ③ | Appearance structure | L: Same to XLH appearance |
| ④ | Performance level | H: Motion control enhanced model |
| ⑤ | I/O points | 24: 12 inputs/12 outputs
30: 14 inputs/16 outputs |
| ⑥ | Connection symbol | A: Axis |
| ⑦ | Control axis number | 8: 8 EtherCAT axis
16: 16 EtherCAT axis
32: 32 EtherCAT axis |

(2) Basic unit model list

◆ XSLH series model list

Model							Input points (DC24V)	Output points (R, T)
AC power supply			DC power supply					
	Relay output	Transistor output	Relay&transistor or mixed output	Relay output	Transistor output	Relay&transistor or mixed output		
NPN & PNP type	-	-	-	-	XSLH-24A8	-	12	12
	-	-	-	-	XSLH-24A16	-	12	12

NPN& differential					XSLH-30A32	-	14	16
----------------------	--	--	--	--	------------	---	----	----

1-2-6. XSLH expansion unit model composition and model table

(1) I/O expansion module

The model composition of I/O expansion module is as follows:

XL	—	<u>E</u>	<u>○</u>	<u>□</u>	<u>○</u>	<u>□</u>	—	<u>○</u>
①	②	③	④	⑤	⑥	⑦		
①	Series name	XL						
②	Expansion module	E						
③	Input points	8 / 16 / 32						
④	Special for input	NPN input: X PNP input: PX						
⑤	Output points	8 / 16 / 32						
⑥	Output mode	YR: relay output YT: transistor output						
⑦	Wiring terminal type	A: horn wiring terminal						

◆ I/O expansion module model list

Model		Function
NPN input	PNP input	
XL-E8X8YR	XL-E8PX8YR	8 channels digital input, 8 channels relay output
XL-E8X8YT	XL-E8PX8YT	8 channels digital input, 8 channels transistor output
XL-E16X	XL-E16PX	16 channels digital input
XL-E16YR	-	16 channels relay output
XL-E16YT	-	16 channels transistor output
XL-E16YT-A	-	16 channels transistor output (horn terminals)
XL-E16X16YT	XL-E16PX16YT	16 channels digital input, 16 channels transistor output
XL-E16X16YT-A	XL-E16PX16YT-A	16 channels digital input, 16 channels transistor output (horn terminals)
XL-E32X	XL-E32PX	32 channels digital input
XL-E32YT	-	32 channels transistor output

(2) Analog, temperature expansion modules

The model composition of analog quantity and temperature expansion module is as follows:

XL—E 4AD 2DA 4PT3 4TC 1WT—P—S

① ② ③ ④ ⑤ ⑥ ⑦ ⑧

- | | |
|----------------------------|--|
| ①: Expansion | E: expansion module |
| ②: Analog input | 4AD: 4 channels analog input
8AD: 8 channels analog input |
| ③: Analog output | 2DA: 2 channels analog output
4DA: 4 channels analog output |
| ④: Temperature measurement | 4PT3: 4 channels platinum thermistor input (3-wire) |
| ⑤: Temperature measurement | 4TC: 4 channels thermocouple Input |
| ⑥: Pressure measurement | 1WT: 1 channel pressure measurement
2WT: 2 channels pressure measurement
4WT: 4 channels pressure measurement |
| ⑦: Model differences | P: with PID control
A: new hardware version (for WT module)
Input is current (for 8AD module)
D: hardware version differences (for WT module)
V: input is voltage (for 8AD module) |
| ⑧: Accuracy | S:16-Bit |

◆ List of analog quantity and temperature expansion module models

Model	Description	
Analog input	XL-E4AD	12-Bit, 4 channels analog input
	XL-E8AD-A	14-Bit, 8 channels analog input, current type
	XL-E8AD-V	14-Bit, 8 channels analog input, voltage type
	XL-E8AD-A-S	16-Bit, 8 channels analog input, current type
	XL-E8AD-V-S	16-Bit, 8 channels analog input, voltage type
Analog I/O	XL-E4AD2DA	4 channels analog input, 2 channels analog output
Analog output	XL-E2DA	2 channels analog output
	XL-E4DA	4 channels analog output
Temperature measurement	XL-E4TC-P	4 channels PT100 temperature measurement, built-in PID control
	XL-E4PT3-P	4 channels PT100 (3-wire) temperature measurement, built-in PID control
Pressure measurement	XL-E1WT-D	1 channel pressure measurement, 0~10mV, 22-bit conversion precision
	XL-E2WT-D	2 channels pressure measurement, 0~10mV, 22-bit conversion precision
	XL-E4WT-D	4 channels pressure measurement, 0~10mV, 22-bit conversion precision

1-2-7. XSA model composition and model table of basic unit

(1) Model composition of basic unit

XS3 series PLC basic unit model composition is generally as follows:

$\frac{\mathbf{X}}{\textcircled{1}} \quad \frac{\mathbf{S}}{\textcircled{2}} \quad \frac{\mathbf{A}}{\textcircled{3}} \quad \frac{\mathbf{3}}{\textcircled{4}} \quad \frac{\mathbf{3}}{\textcircled{5}} \quad \frac{\mathbf{0}}{\textcircled{6}} \text{ — } \frac{\mathbf{W}}{\textcircled{7}}$

- | | |
|-----------------------------|---------------------|
| ① Product type | X: Controller |
| ② Use platform | S: CODESYS |
| ③ AXIS | A: AXIS |
| ④ Appearance structure code | 3: 300 series |
| | 5: 500 series |
| | 2: Economic type |
| ⑤ Performance level | 3: Standard type |
| | 5: Enhancement type |
| | |
| ⑥ Product ID | 0: Product ID |
| ⑦ System | W: Windows system |
| | L: Linux system |

(2) Basic unit model list

- ◆ XSA series model list

Model							Input points (DC24V)	Output points (R, T)
AC power supply			DC power supply					
	Relay output	Transistor output	Relay&transistor mixed output	Relay output	Transistor output	Relay&transistor mixed output		
Bipolar	-	-	-	-	XSA330	-	16	16
	-	-	-	-	XSA520	-	16	16
	-	-	-	-	XSA530	-	16	16
	-	-	-	-	XSA550	-	16	16

1-3. Part introduction

1-3-1. XSDH series structure composition

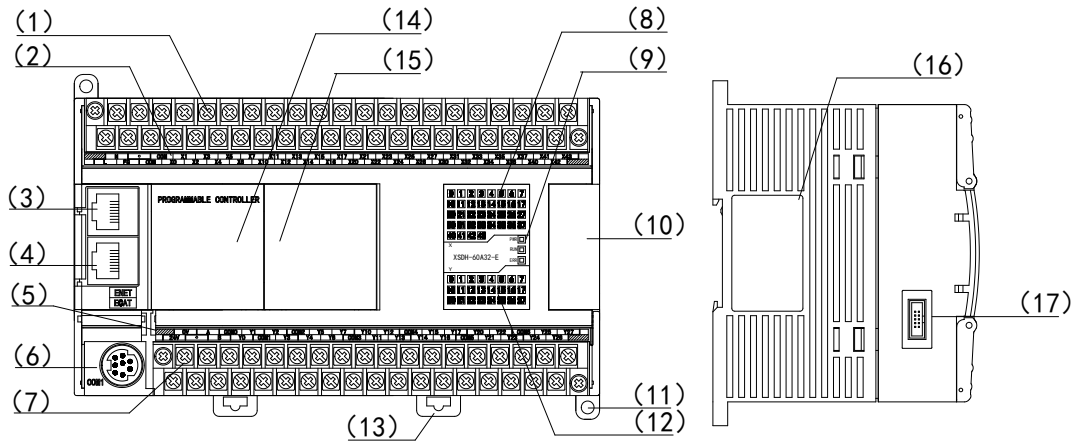

The names of each part are as follows:

- (1): Input terminal, power supply input
- (2): Input label
- (3): RJ45 port 1
- (4): RJ45 port 2
- (5): Output label
- (6): RS232 port (COM1)
- (7): Output terminal, RS485 port (COM2)
- (8): Input action indicator
- (9): System indicator
 - PWR: Power supply indicator
 - RUN: Run indicator
 - ERR: Error indicator
- (10): Expansion module interface
- (11): Installation hole (2 holes)
- (12): Output action indicator
- (13): Guide rail mounting hook (2 hooks)
- (14): Vacant
- (15): Dial switch
- (16): Product label
- (17): Vacant



Note: the dial switch at location (15):

DIP1	DIP2	Function
OFF	OFF	Start PLC normally and use it normally
OFF	ON	The user program is not loaded when the power is on. After the user downloads the empty program, turn the DIP2 to the OFF state and then power on the PLC again
ON	OFF	Initialize the IP to 192.168.6.6 (it takes effect after the PLC is powered on again)

1-3-2. XS3 series structure composition

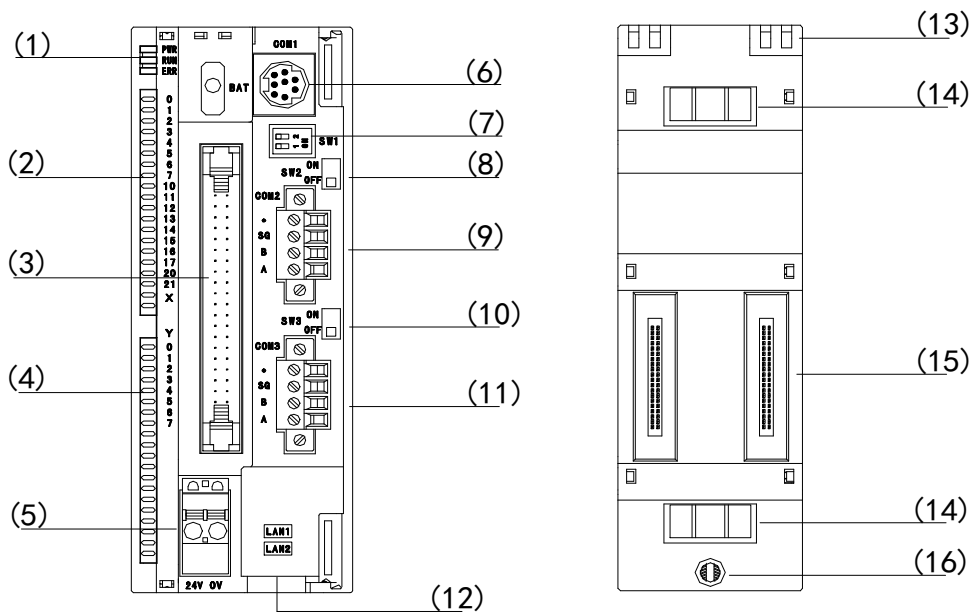

The names of each part are as follows:

- | | |
|----------------------------------|-------------------------------------|
| (1): System indicator | (7): PLC self updating dial switch |
| PWR: power supply indicator | (8): RS485 port (COM2) dial switch |
| RUN: run indicator | (9): RS485 port (COM2) |
| ERR: error indicator | (10): RS485 port (COM3) dial switch |
| (2): Input label and indicator | (11): RS485 port (COM3) |
| (3): I/O wiring terminals | (12): RJ45 port (LAN1, LAN2) |
| (4): Output label and indicator | (13): Installation hook |
| (5): Power supply input terminal | (14): Grounding metal sheet |
| (6): RS232 port (COM1) | (15): Expansion module interface |
| | (16): Mounting screw hole |

Note:

※ 1: when the dial switches SW2 and SW3 are used for RS485 communication, whether the PLC is a terminal. When the PLC is at the beginning or end of the bus, please turn the dial switch to on.

※ 2: Input and output wiring shall be used in conjunction with external terminal blocks and adaptive connecting cables. Refer to section 3-2-4 for details.

1-3-3. XSLH series structure composition

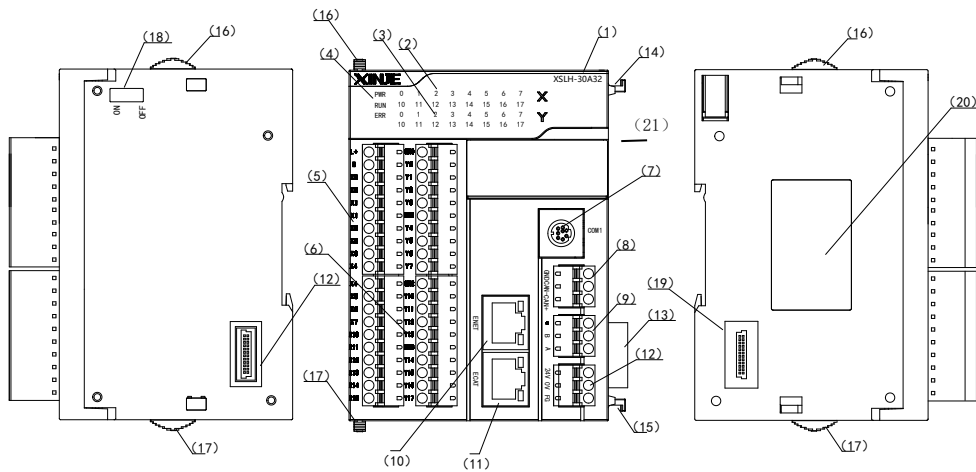

- (1): PLC model
- (2): Input label and indicator
- (3): Output label and indicator
- (4): System indicator
- PWR: power indicator
- RUN: run indicator
- ERR: error indicator
- (5): Input terminals
- (6): Output terminals
- (7): RS232 port (COM1)
- (8): RS485 port (COM2)
- (9): CAN port
- (10): RJ45 port (ENET)
- (11): RJ45 port (ECAT)
- (12): 24V power supply input
- (13): Right expansion module interface
- (14): Fixing module hook (up)
- (15): Fixing module hook (down)
- (16): Sliding latch (up)
- (17): Sliding latch (down)
- (18): Vacant
- (19): Left expansion module interface (COM3)
- (20): Product label
- (21): SD card slot, dial switch

Note:

Location (21) SD card under the cover plate is temporarily closed to users.

The purpose of the dial switch under the cover plate location (21) is as follows:

DIP1	DIP2	Function
OFF	OFF	Start the PLC normally and use it normally
OFF	ON	The user program is not loaded after power on. After the user downloads the empty program, turn DIP2 to OFF and power on the PLC again
ON	OFF	The initialization IP is 192.168.6.6 (it takes effect after the PLC is powered on again)

DIP3	DIP4	Function
OFF	OFF	Start the PLC normally and use it normally
ON	ON	Terminal resistance of CAN OPEN

1-3-4. XSA series structure composition

1-3-4-1. XSA series interface structure composition

(1) XSA330

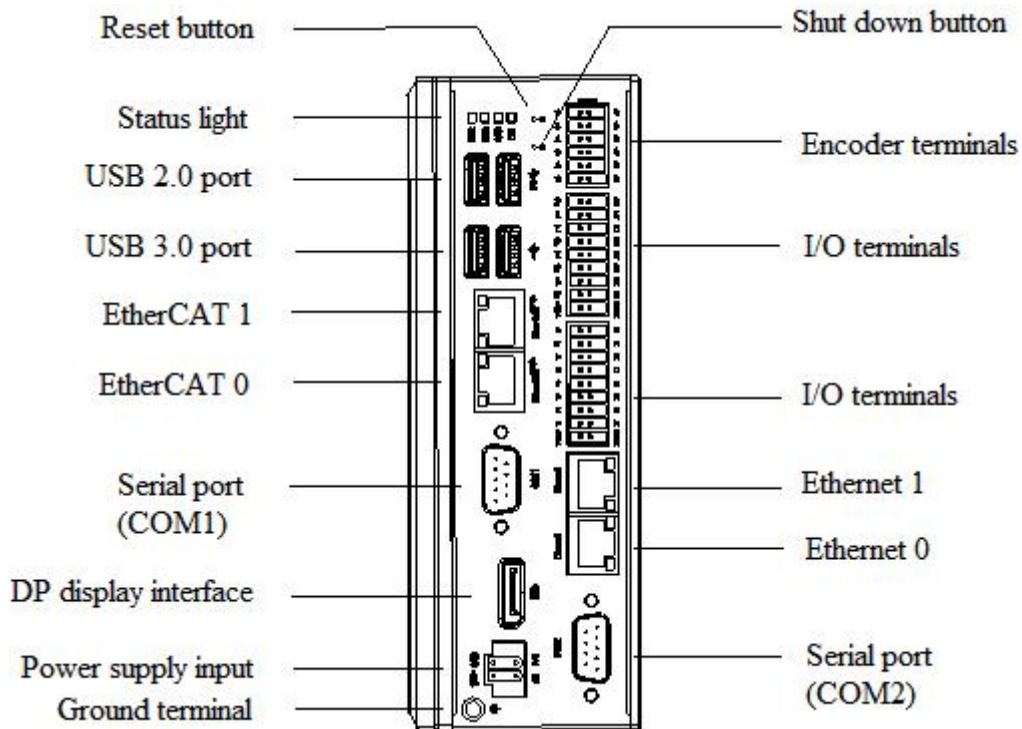

(2) XSA500

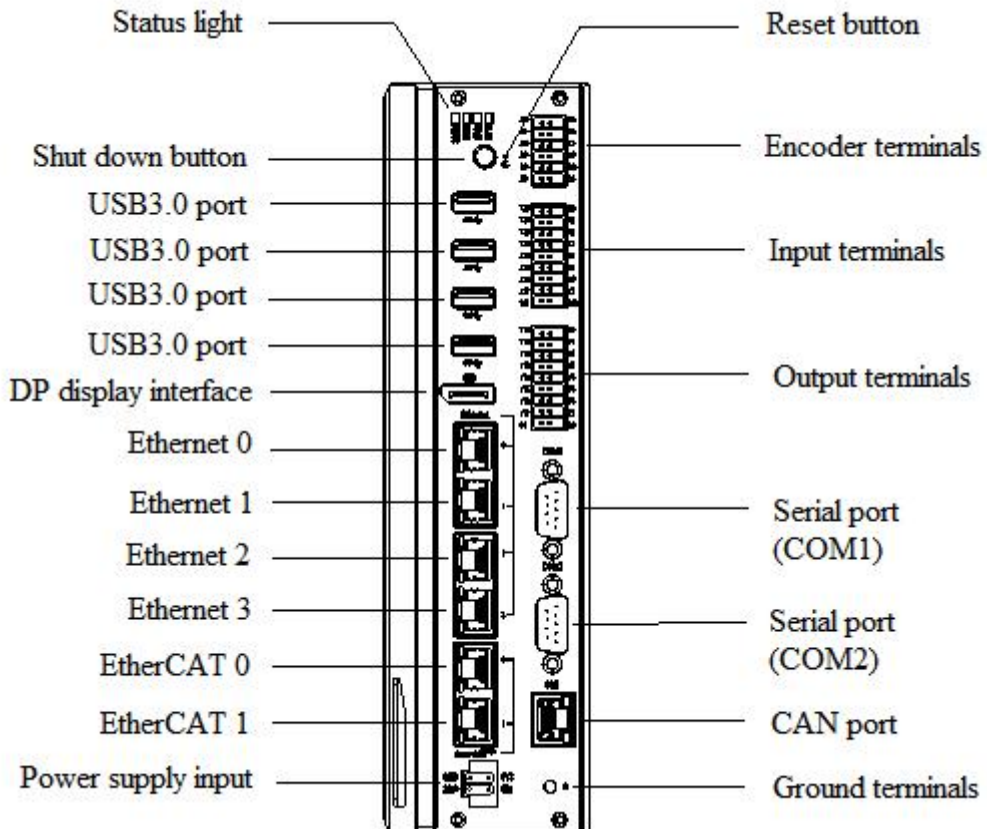

1-3-4-2. LED indicator light

XSA series has 4 LED status indicators, as shown below.

(1) XSA330 indicator light



LED	Status indicator	Description
PWR	Power supply	<u>Green normally on:</u> Shutdown. After the shutdown is completed, the light goes out. <u>Green normally on:</u> System work normally <u>Red normally on:</u> Not enter the system or the system is abnormal
SATA	SATA hard disk detection	<u>Green flashing:</u> Data interaction <u>OFF:</u> No data
RUN	Run indicator	<u>Green normally on:</u> Run normally <u>OFF:</u> Error (Program exception Stop)
ERR	Error indicator	<u>Red normally on:</u> Error <u>OFF:</u> No error

(2) XSA500 indicator light



LED	Status indicator	Description
SATA	SATA hard disk detection	Data interaction: flashing; No data: Off
RUN	Run indicator	Standby: off; Normal operation: Always on
ERR	Error indicator	Normal: off; Error: Always on
UPS	Power supply status	UPS ready: always on; UPS power supply: flashing

1-3-4-3. Reset button

XSA series is equipped with a Reset key (pinhole structure). Short press can restart the system. Long press can reset the BIOS (clear CMOS) in power off status, as shown below:



CMOS is powered by the button battery on the motherboard. Clearing CMOS will permanently erase the previous system settings and set them to the original (factory setting) system settings. The steps

are as follows:

- ① Turn off the controller and disconnect the power.
- ② Press the Clear CMOS key for 3-5 seconds with a slender pin, and then release it.
- ③ Start the controller, press the [Del] key to enter BIOS settings during startup, and reload the optimal default value.
- ④ Save and exit settings.

1-3-4-4. Power supply input

XSA series is equipped with a 24V 4 PIN phoenix terminal, as shown below.

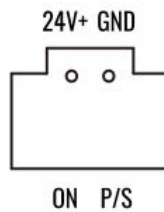

Please use the adapter or switch power supply provided with the device, and do not connect the power supply with a voltage exceeding 25.2V, otherwise the motherboard will be burnt due to overvoltage.

Signal	Description
24V+	Power Supply
GND	0V
ON	PC_ON 3V output
P/S	24V 1A output

Terminal description:

- ① 24V and GND: IPC power supply
- ② ON and GND: IPC ON/OFF
- ③ P/S and GND: Series indicator lights display system operation status

1-3-4-5. DP interface

XSA series is equipped with a DP display interface, which can realize high-definition transmission of signals at high speed, and also has good anti-interference capability.

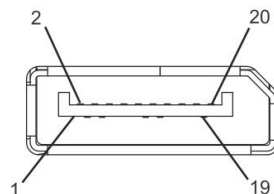

Pin	Signal name	Function	Pin	Signal	Function
1	ML_Lane 0(p)	True signal of channel 0	11	GND	Ground
2	GND	Ground	12	ML_Lane 3(n)	Auxiliary signal of channel 3
3	ML_Lane 0(n)	Auxiliary signal of channel 0	13	GND	Ground

Pin	Signal name	Function	Pin	Signal	Function
4	ML_Lane 1(p)	True signal of channel 1	14	GND	Ground
5	GND	Ground	15	AUX_CH(p)	Real signal of auxiliary channel
6	ML_Lane 1(n)	Auxiliary signal of channel 1	16	GND	Ground
7	ML_Lane 2(p)	True signal of channel 2	17	AUX_CH(n)	Auxiliary signal of auxiliary channel
8	GND	Ground	18	Hot Plug	Hot plug detection
9	ML_Lane 2(n)	Auxiliary signal of channel 2	19	DP_PWR Return	Interface power return
10	ML_Lane 3(p)	True signal of channel 3	20	DP_PWR	Connector power supply

1-3-4-6. Ethernet interface (LAN)

XSA series is equipped with 4 Ethernet interfaces (2*Ethernet+2*EtherCAT), as shown below, supporting 10/100/1000Mbps and conforming to IEEE 802.3az. The port adopts a standard RJ-45 jack with LED indicators to indicate the connection and transmission status.

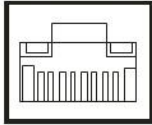
	LED indicator	
	Left LED	Right LED
	Orange	Green
	10 /100/1000 Link	Transmission

RJ45 port	Function	
Ethernet	Support Modbus-TCP, UDP and other communication protocols. It can be used to upload and download programs, online monitoring, remote monitoring, etc.,and can communicate with other TCP IP devices in the LAN.	
	Item	Parameter
	Communication protocol	MODBUS TCP
	Communication speed	1000Mbps
	Max network nodes	30
	Max station spacing	100m
	Network topology	Linear

EtherCAT	EtherCAT bus control, control cycle \leq 1ms	
	Item	Specification
	Physical layer	100BASE-TX (IEEE802.3)
	Baud rate	1000[Mbps] (full duplex)
	Topology	Line
	Cable	JC-CB twisted pair (shielded twisted pair)
	Cable length	Up to 100m between nodes
	Com port	1Port (RJ45)
	EtherCAT Indicators (LED)	[Run] RUN Indicator [L/A IN] Port0 Link/Activity Indicator (Green) [L/A OUT] Port1 Link/Activity Indicator (Green)
	Station Alias (ID)	Range: 0~65535 Address: 2700h
	Explicit Device ID	Not support
	SyncManager	4
	FMMU	3
	Touch Probe	2 channels
	Synchronization mode	DC (SYNCO event synchronization) SM (SM event synchronization)
	Cyclic time (DC communication cycle)	500, 1000, 2000, 4000[μ s]
	Communication object	SDO[Service data object], PDO[Process data object]
	Max allocated number of single station PDO	TxPDO: 4 [pcs] RxPDO: 4 [pcs]
	Mailbox communication interval in PreOP mode	1ms
	E-mail	SDO request and SDO information

1-3-4-7. USB interface

XSA330 is equipped with two USB 2.0 and two USB 3.0 interfaces. XSA500 comes with 4 USB 3.0 interfaces. The USB interface supports the plug and play function, allowing users to connect or disconnect the device at any time without shutting down the controller. USB interface conforms to USB EHCI, Rev 2.0 Standards. Pins are defined as follows.

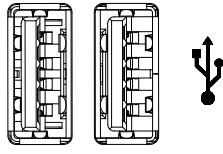
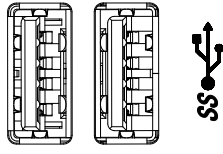
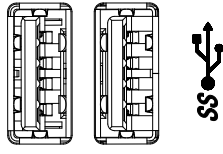
		USB2.0		
		Pin	Signal	Function
		1	VCC	Power supply
		2	DATA-	Differential signal
		3	DATA+	
		4	GND	Ground
		USB3.0		
		Pin	Signal	Function
		1	VCC	Power supply
		2	DATA-	Differential signal
		3	DATA+	
		4	GND	Ground
		5	SSRX-	High speed receiving differential data signal
		6	SSRX+	
		7	GND	Ground
		8	SSTX-	High speed sending differential signal
9	SSTX+			

1-3-4-8. Serial port

XSA series is equipped with corresponding RS232 and RS485 communication serial ports. For DB9 serial ports, the change of BIOS settings can realize the switching function between RS232 and RS485, and realize the communication between devices.

Series	Default	
	DB9 interface(RS232)	DB9 interface(RS485)
XSA [※]	2	0

※:

The two DB9 interfaces default to RS232 serial ports. If you need RS485 serial port, please modify it in the BIOS path in Advanced>Super IO Configuration>Serial Port 1 Configuration>COM Mode>RS485 Mode.

DB9 communication port(RS232/RS485)

The pin definitions are as follows:

XSA330 series:

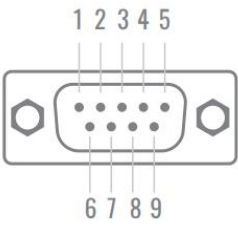
	Pin	RS232(DB9)	Description	RS485(DB9)	Description
	1	DCD	Carrier detection	DATA-	B: RS485-
	2	RXD	Receive data	DATA+	A: RS485+
	3	TXD	Send data	NC	/
	4	DTR	Data terminal ready	NC	/
	5	GND	Signal ground	GND	Signal ground
	6	DSR	Data ready	NC	/
	7	RTS	Send request	NC	/
	8	CTS	Clear send	NC	/
	9	RI	Ringing prompt	NC	/

XSA500 series:

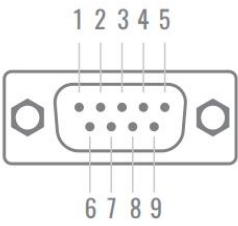
	Pin	RS232(DB9)	Description	RS485(DB9)	Description
	1	NC	/	NC	/
	2	RXD	Receive data	NC	/
	3	TXD	Send data	NC	/
	4	NC	/	A	RS485+
	5	GND	Signal ground	GND	Signal ground
	6	NC	/	NC	/
	7	NC	/	B	RS485-
	8	NC	/	NC	/
	9	NC	/	NC	/

【Note】 : NC means no connection.

2. Main body specification parameters

2-1. Specification parameters

2-1-1. General specification

This specification parameter table is also applicable to XSDH, XSLH and XS3 series PLC.

	Specification		
	XS3/XSDH/XSLH	XSA330 series	XSA500 series
Anti-noise	Noise voltage 1000Vp-p 1us pulse 1 minute		
Air	No corrosive and combustible gas		
Working temperature	0°C~55°C	-25°C~60°C	-25°C~60°C
Storage temperature	-40°C~80°C	-40~+80°C	-40~+80°C
Ambient humidity	5%~95% (no condensation)		
Installation	Fix with M3~M4 screws		Ear hanging installation
Grounding (FG)	The third type of grounding (It shall not be grounded in common with strong current system)※		

Note: Separate grounding or common grounding shall be adopted for grounding, and public grounding shall not be adopted.

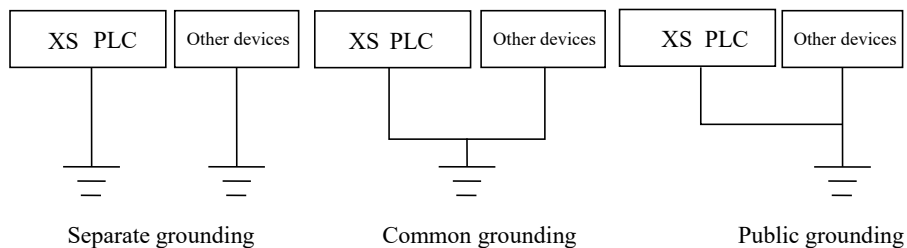

2-1-2. Performance specification

Item	XSDH-60A32-E	XS3-26T4	XSLH-24	XSLH-30A32	
Programming method	ST, SFC, FBD, CFC, LD, IL				
Main processor	1GHz	800MHz	800MHz	1GHz	
User program capacity※ ¹	32MB				
Data capacity	32MB				
Power-off holding capacity	6MB				
I/O ※ ²	Total	60 points	26 points	24 points	30 points
	Input	36 points X0~X43	18 points X0~X21	12 points X0~X13	14 points X0~X15
	Output	24 points Y0~Y27	8 points Y0~Y7	12 points Y0~Y13	16 points Y0~Y17
EtherCAT slave stations	32	32	24A8: 8 24A16: 16	32	

Item	XSDH-60A32-E	XS3-26T4	XSLH-24	XSLH-30A32
High speed processing function	High speed counting, external interruption	High speed counting, external interruption	High speed counting, pulse output, external interruption	High speed counting, external interruption
External interrupt point	X2~X7, X10~X13, X16, X21, X24, X27	X2, X5, X10, X13, X16, X21,	X2~X7, X10~X13	

Item	XSA330	XSA520	XSA530	XSA550
Programming method	ST, SFC, FBD, CFC, LD, IL			
Main processor	1.5GHz	3GHz	2.4GHz	2.8GHz
User program capacity ^{※1}	128MB			
Data capacity	128MB			
Power-off holding capacity	6MB			
I/O ^{※2}	Total	32 points		
	Input	16 points X0~X17		
	Output	16 points Y0~Y17		
EtherCAT slave stations	64	64	128	256
High speed processing function	High speed counting, external interruption			
External interrupt point	X0~X7, X10~X17			

Note: I/O points refer to the number of terminals that users can access and output signals from outside.

2-2. Dimension

2-2-1. XSDH series PLC dimension

(Unit: mm)

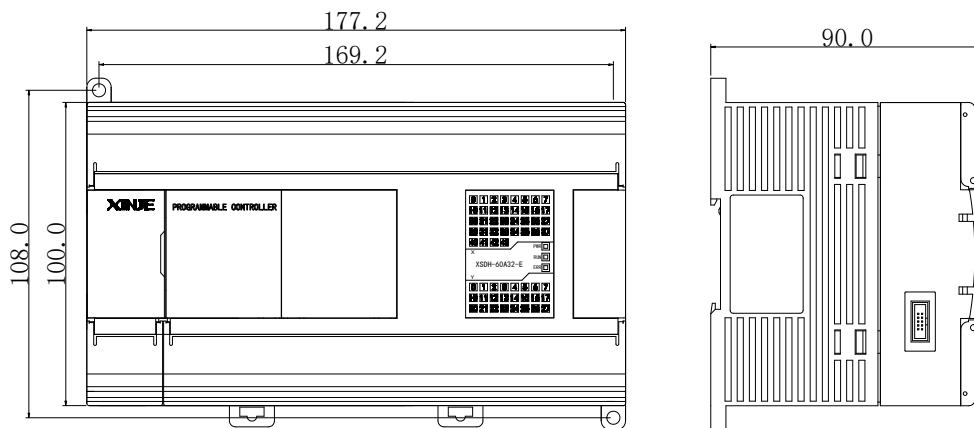

2-2-2. XS3 series dimension

(Unit: mm)

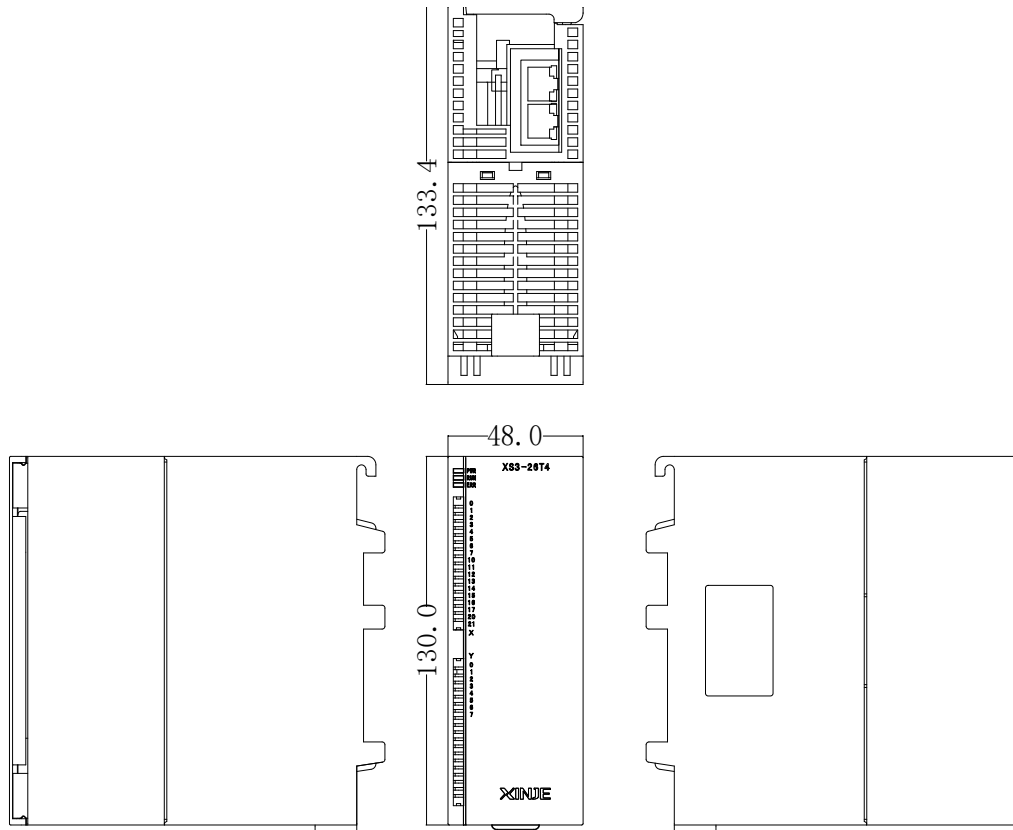

2-2-3. XSLH series PLC dimension

(Unit: mm)

- XSLH-24A8

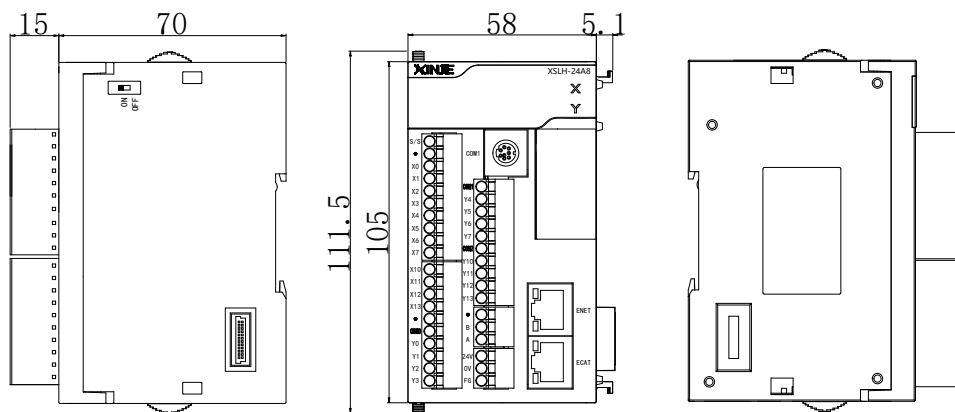

- XSLH-24A16

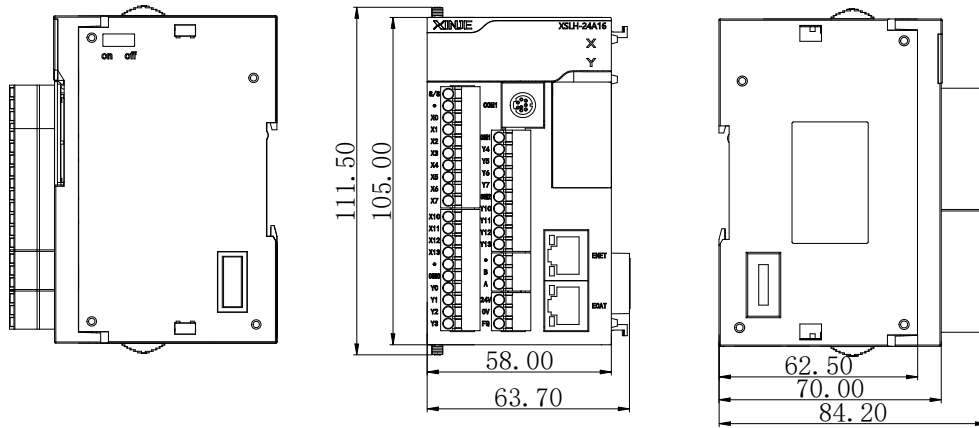

- XSLH-30A32

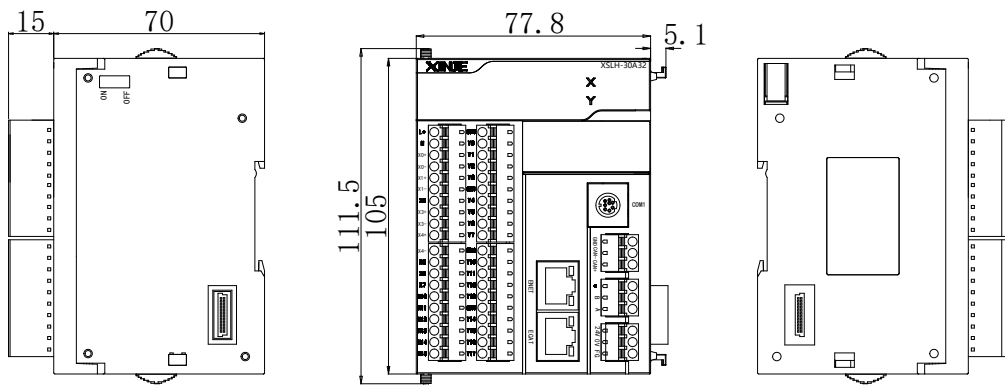

2-2-4. XSA series PLC dimension

(Unit: mm)

- XSA330

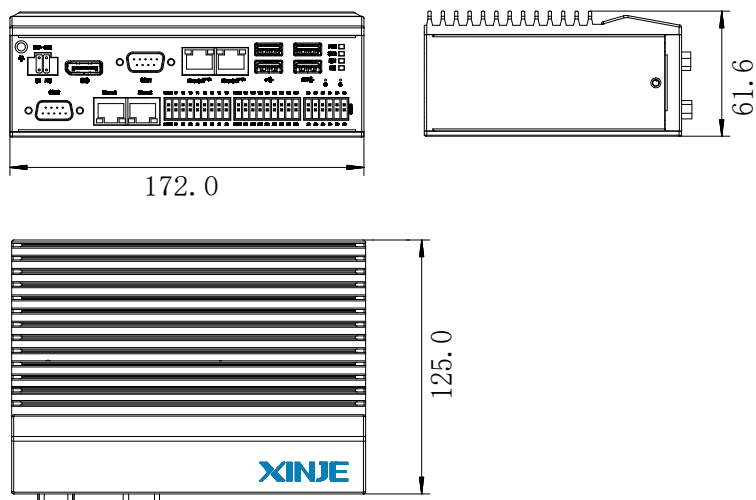

- XSA500

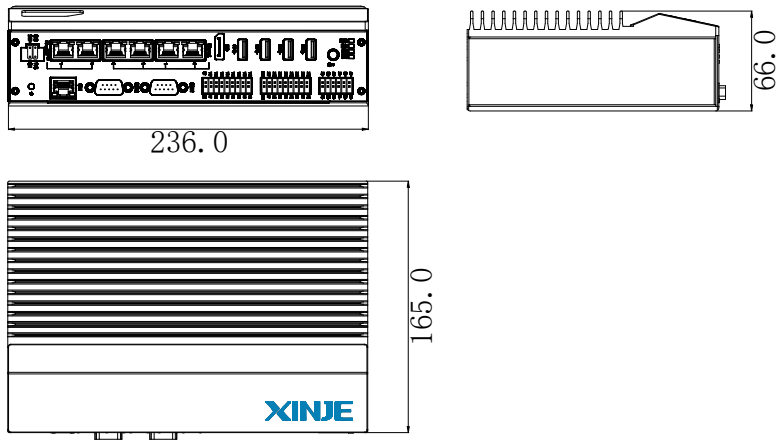

2-3. Terminal arrangement

2-3-1. XSDH series terminal arrangement

	N	COM	X0	X1	X2	X3	X4	X5	X6	X7	X10	X11	X12	X13	X14	X15	X16	X17	X20	X21	X22	X23	X24	X25	X26	X27	X30	X31	X32	X33	X34	X35	X36	X37	X40	X41	X42	X43		
	L	F6	COM	X0	X1	X2	X3	X4	X5	X6	X7	X10	X11	X12	X13	X14	X15	X16	X17	X20	X21	X22	X23	X24	X25	X26	X27	X30	X31	X32	X33	X34	X35	X36	X37	X40	X41	X42	X43	
	0V	A	COM0	Y1	Y2	COM2	Y5	Y7	Y10	Y12	COM4	Y15	Y17	Y20	Y22	COM6	Y25	Y27																						
	24V	B	COM1	Y0	Y3	Y4	Y6	COM3	Y11	Y13	Y14	Y16	COM5	Y21	Y23	Y24	Y26																							

Note: refer to chapter 5-1 for details.

2-3-2. XS3 series terminal arrangement

(1) Main body terminals

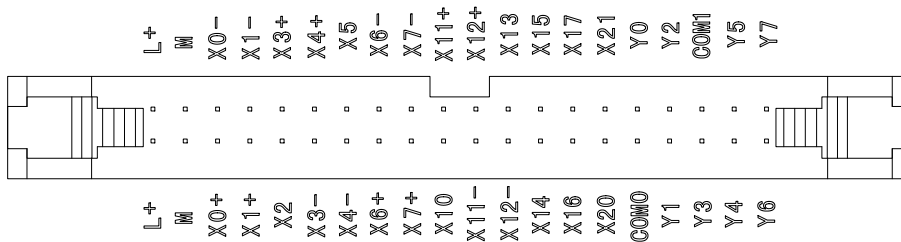

(2) External terminal block

L+	X0+	X1+	X2	X3-	X4-	X6+	X7+	X10	X11-	X12-	X14	X16	X20	COM0	Y1	Y3	COM1	Y5	Y7
M	X0-	X1-	X3+	X4+	X5	X6-	X7-	X11+	X12+	X13	X15	X17	X21	Y0	Y2	•	Y4	Y6	•

Note:

※1: COM0 at the output terminal corresponds to Y0~Y3, and COM1 corresponds to Y4~Y7

※2: Refer to chapter 5-1 for wiring details.

2-3-3. XSLH series terminal arrangement

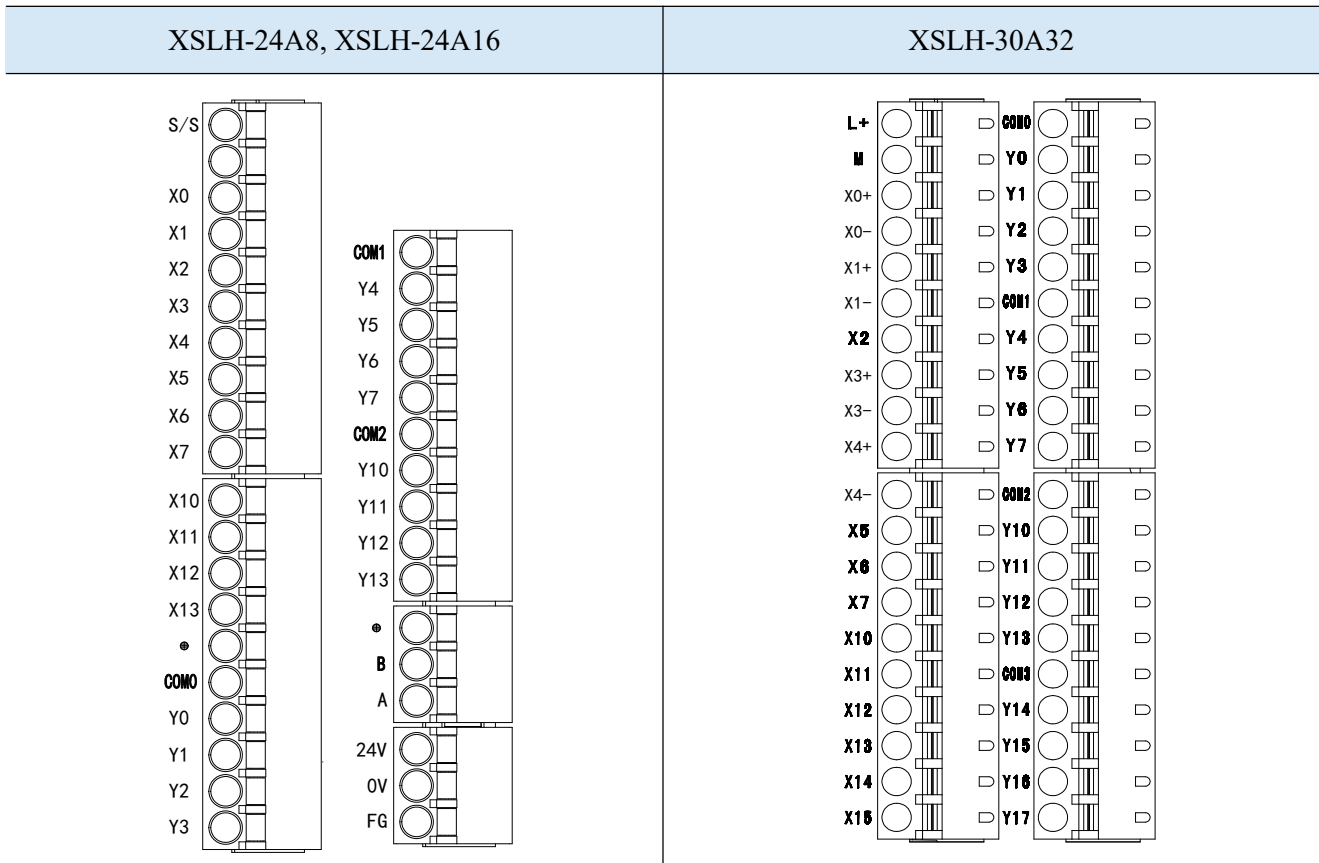

Note: refer to chapter 5-1 for details.

2-3-4. XSA series terminal arrangement

2-3-4-1. I/O terminal

The XSA series is equipped with 16 sets of digital I/Os, among which X0~X7 are 200KHz high-speed inputs. The I/O is used to trigger, control, and count for data acquisition functions. The interfaces are shown in the table below:

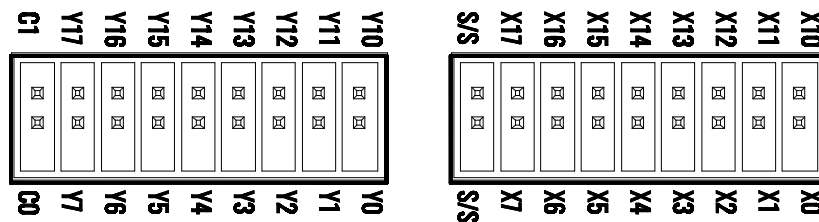

2-3-4-2. Encoder

XSA series is equipped with two sets of three-phase encoders, and through the dual differential encoder interface, closed-loop control of position locking can be achieved. The interfaces are shown in the table below:

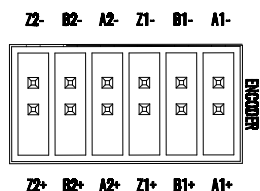

2-4. Communication ports

XS series generally has COM1 (RS232), COM2 (RS485) and 2~6 LAN ports (RJ45). COM1 and COM2 are mainly used for communication. Ethernet port can connect PLC to LAN or realize EtherCAT communication.

(1) RS232 port

XS series PLC has one RS232 port (COM1), which is used to connect HMI or some meters, and supports MODBUS communication modes.

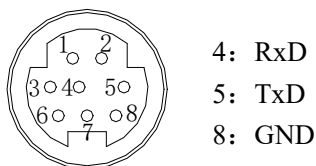

Mini Din 8-core plug

(2) RS485 port

On the output terminal block, terminals are A and B, where A is RS485+, and B is RS485-. It can be used to connect the touch screen, communicate with some instruments, etc.

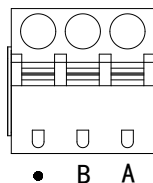

(3) LAN port

Ethernet RJ45 port: the Ethernet port is RJ45 interface, with stable and convenient communication mode. It can be used for uploading and downloading programs, online monitoring, remote monitoring, etc., and can communicate with other TCP IP devices in the LAN.

EtherCAT communication port: the EtherCAT communication port is an RJ45 interface with convenient communication connection mode and can communicate with other equipment supporting EtherCAT communication.

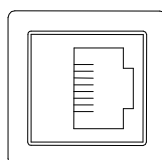

Model	XSDH, XS3, XSLH	XSA330	XSA500
LAN1	Ethernet RJ45 port	Ethernet RJ45 port	Ethernet RJ45 port
LAN2	EtherCAT port	Ethernet RJ45 port	Ethernet RJ45 port
LAN3	-	EtherCAT port	Ethernet RJ45 port
LAN4	-	EtherCAT port	Ethernet RJ45 port
LAN5	-	-	EtherCAT port
LAN6	-	-	EtherCAT port

(4) CAN port

XSLH-30A32 has a CAN communication port with terminals GND, CAN+, and CAN-, which can communicate with other devices that support CANopen communication .

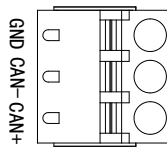

3. System composition

3-1. System composition

The following figure is the system structure diagram constructed according to the basic configuration of XS3 series PLC. Through this diagram, you can roughly understand the connection between PLC and peripheral equipment, expansion equipment, etc., as well as the typical applications of PLC communication, connection and expansion ports.

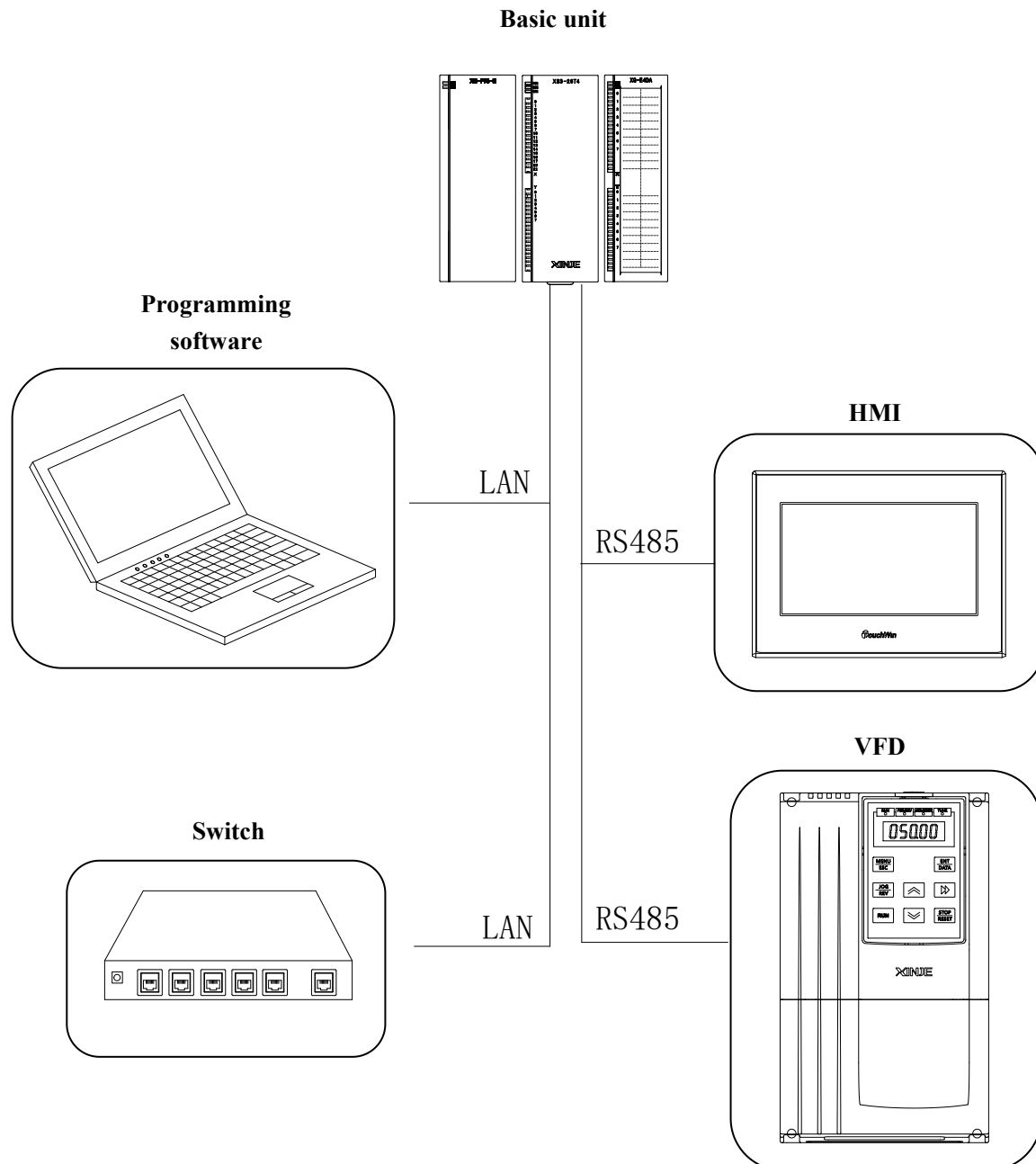

Note: The connecting devices of the above communication ports are only used as examples. The actual communication ports can connect a variety of devices.

3-2. Peripherals

The use of basic units of XSDH, XSLH, XS3, XSA series PLC involves a variety of peripheral devices.

3-2-1. Programming software

In Codesys programming software, functions such as writing or uploading programs to XS series PLC, real-time monitoring PLC operation, configuring PLC, etc. can be realized.

- ◆ Software interface

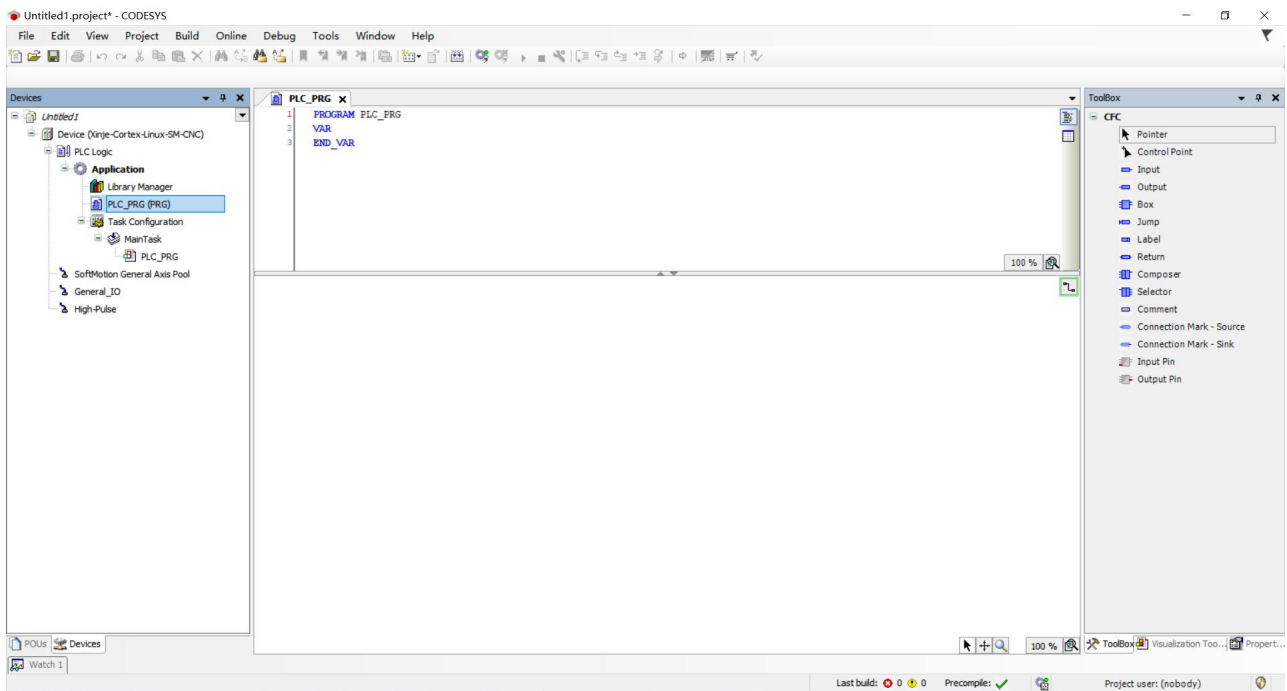

3-2-2. HMI

The HMI is an interactive interface between PLC and operators. The HMI can easily and quickly send the operator's instruction to the PLC, and then the PLC executes the action.

The basic unit of XS series PLC supports the connection of various HMI. The connection is established on the basis of consistent communication protocols, generally through Modbus TCP protocol. The specific parameters depend on the HMI connection.

The HMI of Xinje company can be directly connected with the basic unit for communication (the communication parameters have been consistent). At present, Xinje HMI products are divided into touch screen TG, TS series and text display OP series.

(1) TG series

- ◆ Size: 4.3", 7", 8", 10.1", 15.6"
- ◆ Display: 16.77 million colors, 65536 colors
- ◆ Operation: touch operation in display area
- ◆ Interface: RS232, RS422, RS485, USB, RJ45
- ◆ Communication: it can communicate directly with Xinje frequency converter, various PLCs, frequency converters and instruments. Direct drive panel printer, supporting multiple printers. Equipped with two ports, which can connect two different devices at the same time. Support free format protocol, and users can freely write drivers.

- ◆ Recipe: multiple groups of recipe data can be input, to find the corresponding recipe group through the index number
- ◆ Screen: rich 3D image library, text effects, data collection, data backup, etc
- ◆ Password: nine level permission setting
- ◆ Advance: advanced functions, animation track design, etc

(2) TS series

- ◆ Size 7", 10.1"
- ◆ Display 16.77 million colors
- ◆ Touch operation in the operation display area
- ◆ Interface RS232, RS422, RS485, USB-A, USB-B, Ethernet interface
- ◆ Communication can directly communicate with Xinje frequency converters, various PLCs, frequency converters, and instruments
Directly drive panel printers, supporting multiple printers
Equipped with dual ports, capable of connecting 2 different devices simultaneously
Support for free format protocol, allowing users to freely write driver programs
Supports OPCUA and PLChandler protocols, supports label communication
- ◆ Recipes are written directly through a recipe table
- ◆ 3D library with rich visuals, including text effects, data collection, and data backup
- ◆ Password permission list, supporting up to 30 types of permissions
- ◆ Advanced Multilingual Library, Address Label Library, Support Function Block

(3) OP series

- ◆ Size: 3.7"
- ◆ Display: STN-LCD
- ◆ Button: 7 or 20, screen cannot be touched
- ◆ Interface: RS232, RS485, RS422
- ◆ Communication: directly communicate with various PLC and Xinje frequency converter
- ◆ Clock: Built-in clock

3-2-3. Power supply module

3-2-3-1. XSLH series power supply module

The XSLH series PLC is equipped with a dedicated power module, model XL-P50-E, and its basic specifications are as follows:

Item	Specification
Power supply	AC85-265V
Output voltage	DC24V
Output current	2A
Ambient temperature	Non corrosive and flammable gases
Ambient humidity	0°C~55°C
Installation	5%RH~95%RH (no condensation)
Installation	Directly installed on DIN46277 guide rail (35mm wide)
Ground	The third type of grounding (cannot be connected to a common ground with a strong electrical system)

Structure description:

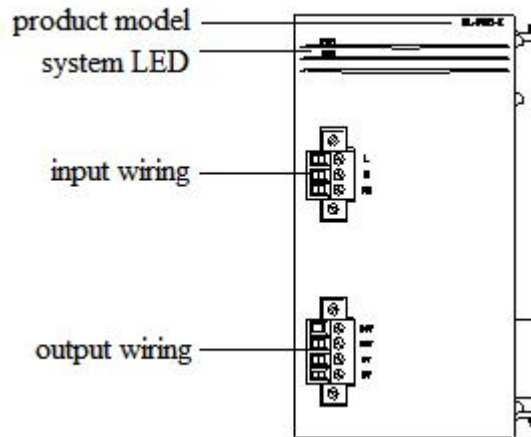

The main parts are explained as follows:

Name	Function
Product model	The specific model of the product
System LED	PWR: Power indicator light, green always on after supplying power to the power module RUN: Running indicator light, green always on when the power module is running normally
Input wiring	L, N: External power supply input terminal of the power module FG: Grounding terminal
Output wiring	Can output 2 sets of 24V and 0V externally, mainly providing power to the XL body

Dimension:

Unit: mm

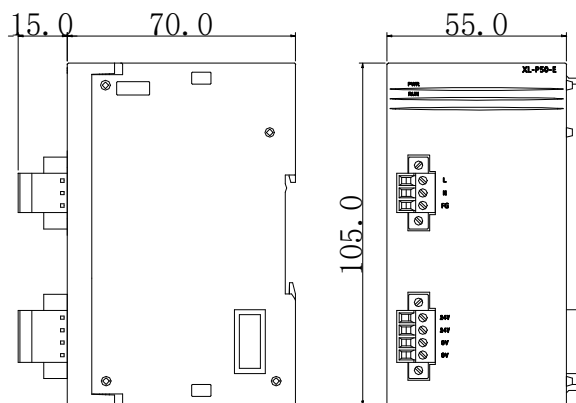

3-2-3-2. XS3 series power supply module

XS3 series medium-sized PLC is equipped with a special power module, the model is XG-P75-E, and its basic specifications are as follows:

Item	Specification
Power supply	AC100~240V
Output voltage	24VDC
Output power	75W
Ambient temperature	0°C~60°C
Ambient humidity	5%RH~95%RH (no condensation)
Installation	Directly installed on Xinje XG-EB series guide rail

■ Structure description

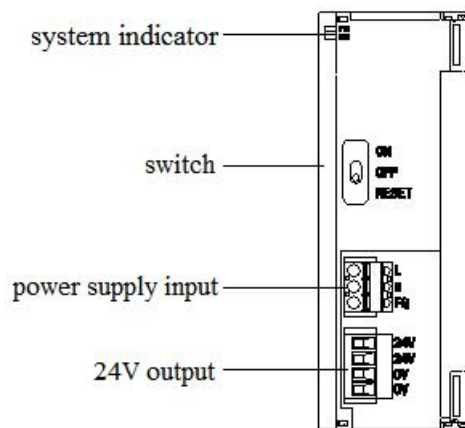

The main parts are described as follows:

Name	Explanation
System indicator	PWR: the power indicator is always green when AC220V power is connected RUN: the operation indicator light is always green when the power module is in normal operation
Switch	ON: normal output 24V OFF: stop output 24V RESET: undefined
Power supply input	L, N: power supply input terminal FG: grounding terminal
24V output	24V, 0V: a group of 24VDC power supply can be output to supply power to XS3 body

■ Dimension

(Unit: mm)

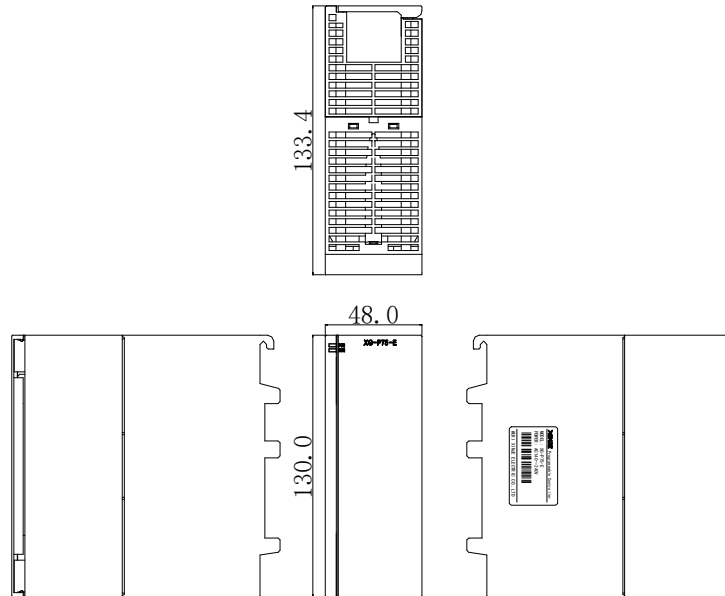

3-2-4. Terminal block and connection cable

External terminal blocks can be selected for XS3 series wiring. Xinje provides terminal blocks and connecting cables required by XS3 for users to choose.

List of terminal blocks and connecting cable models:

Main body	Terminal block	Connection cable
XS3-26T4	JT-G26	JC-G26-NN05 (0.5m)
		JC-G26-NN10 (1.0m)
		JC-G26-NN15 (1.5m)

(1) Terminal block

■ Terminal arrangement of terminal block

L+	X0+	X1+	X2	X3-	X4-	X6+	X7+	X10	X11-	X12-	X14	X16	X20	COM0	Y1	Y3	COM1	Y5	Y7
M	X0-	X1-	X3+	X4+	X5	X6-	X7-	X11+	X12+	X13	X15	X17	X21	Y0	Y2	•	Y4	Y6	•

Note: COM0 at the output terminal corresponds to Y0~Y3, and COM1 corresponds to Y4~Y7.

■ Terminal block dimension

Unit: mm

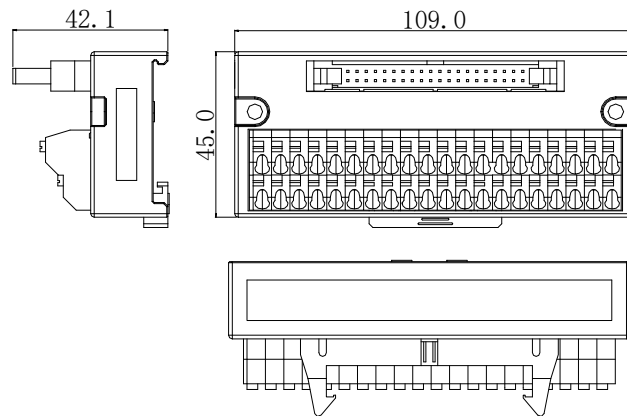

■ Wiring method

When wiring, press the spring switch with screw driver, insert the wire into the corresponding hole, and release the spring switch. The terminal block requires that the stripped length of the conductor is 1.5cm.

■ Installation

The terminal block shall be installed on a 35mm wide guide rail.

(2) Connection cable

Connecting cables shall be used in conjunction with external terminal blocks. Xinje provides JC-G26-NN05, JC-G26-NN10, JC-G26-NN15 cables of different lengths and specifications for users to choose. Please note that when connecting, one end of the model wrapped by a transparent heat shrinkable tube is connected to XS, and the other end is connected to the terminal block. Do not reverse the connection!!!

The connection diagram is as follows:

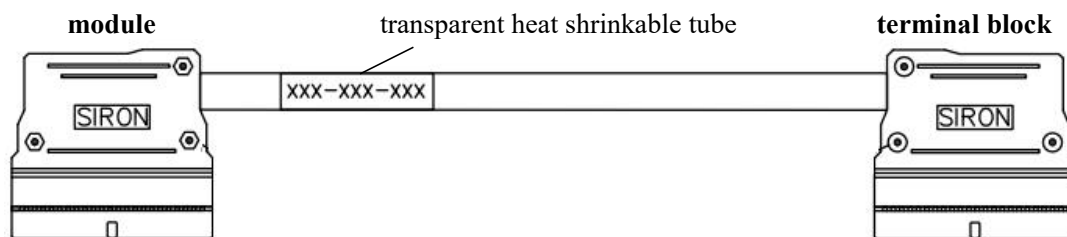

Note: When connecting with the terminal block, please pay attention to the slot position of the terminal block, and do not reverse the connection.

3-3. Constitution principle

(1) About communication port

- ◆ The basic units of XSDH/XS3/XSLH series are generally equipped with multiple communication ports, including COM1, COM2, COM3, etc.
- ◆ Most communication ports can be used for programming download and communication.
- ◆ Each port is independent of each other.

(2) About expansion devices

- ◆ Generally speaking, the basic unit can be expanded with different types of expansion modules, or mixed expansion, input and output expansion, analog and temperature expansion.
- ◆ The XSDH/XS3/XSLH series can expand up to 16 modules.
- ◆ After connecting the basic unit and the expansion module with the bus connector, the PWR indicator of the expansion module is on, and the expansion module can be used normally.

(3) About the calculation of points

- ◆ Points are the actual input and output points.
- ◆ When the expansion module is connected, the total number of points = the number of points of the basic unit + the number of points of the expansion module.
- ◆ The serial number of input / output digital value is octal.
- ◆ The serial number of input and output analog quantity is decimal.

Point calculation example

Basic unit XS3-26T4 (18I/8O) connects 5 XG-E8X8YR modules, the total points will be:

Input points: $18 + 8 * 5 = 58$

Output points: $8 + 8 * 5 = 48$

Total points: $58 + 48 = 106$

3-4. Product installation

3-4-1. Installation location

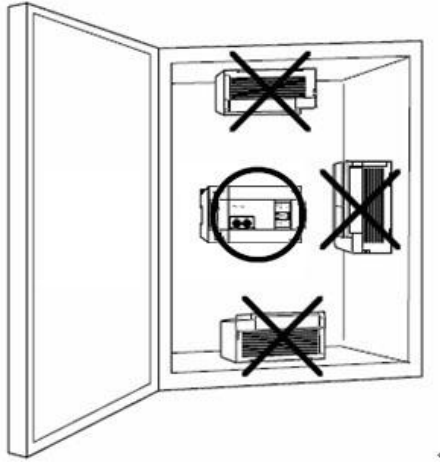

3-4-2. Installation method

(1) XSDH series installation

For the installation of XSDH series basic unit and expansion module, guide rail installation or direct screw installation can be selected.

- ◆ Install with DIN46277 guide rail

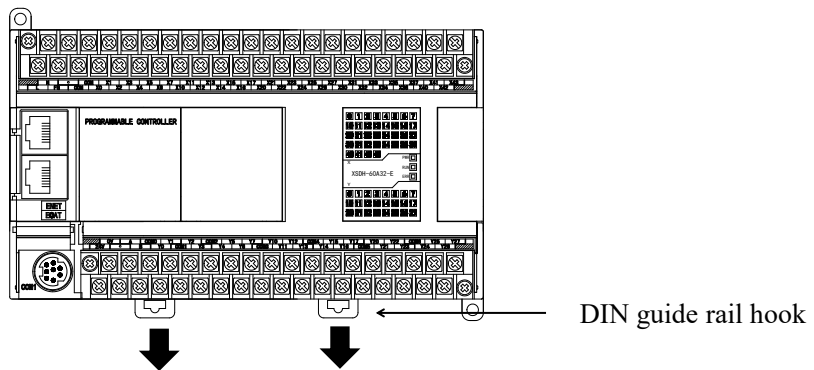

The unit and expansion module are installed on DIN46277 guide rail (35mm wide). To remove, just pull down the assembly hook of the DIN rail and remove the product.

- ◆ Screw direct installation

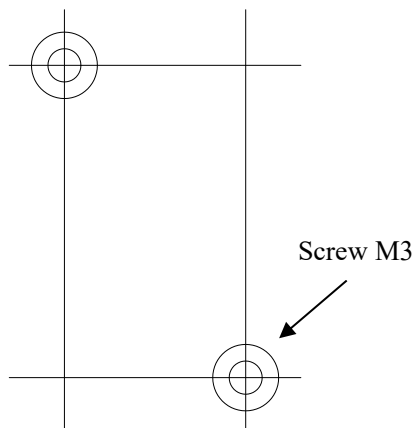

(2) XS3 series installation

The XS3 series basic unit and expansion module are installed with XG-EB series guide rails.

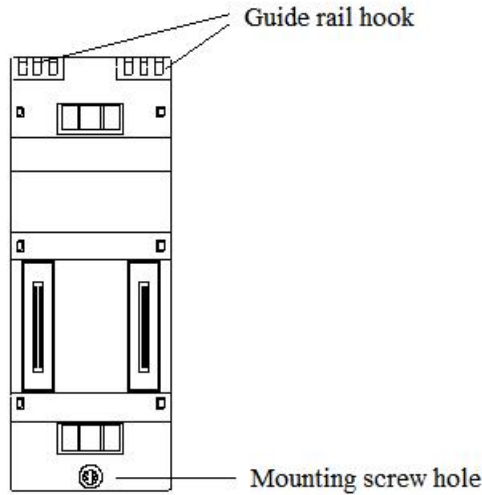

Connect the power module, XS3 body and XG expansion module to the guide rail through the U-connector, and fix them with the bottom screw. The installation steps are as follows:

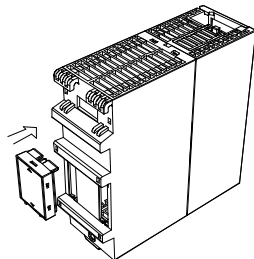
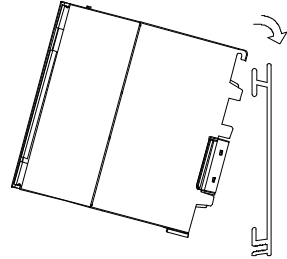
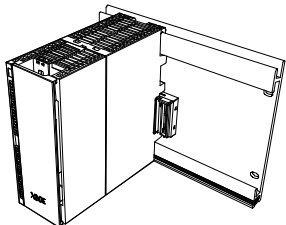
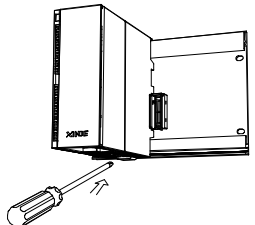
<p>① Insert the L Port of the U-shaped connector into the left interface on the back of the PLC body. (on the right in front view)</p>	<p>② Hang the installation hook on the upper side of the PLC body to the upper side of the installation guide rail according to the direction shown in the figure</p>
	
<p>③ Fix the PLC to the mounting rail as shown in the following figure</p>	<p>④ Screw holes under PLC shall be fixed with screws</p>
	
<p>⑤ Plug the L Port of the U-connector into the left interface on the back of the #1 expansion module (on the right in front view)</p>	<p>⑥ Hang the installation hook on the upper side of the #1 module to the upper side of the installation guide rail according to the direction shown in the figure. The expansion port on the left side of the module is connected with the R port of the U-connector on the body</p>

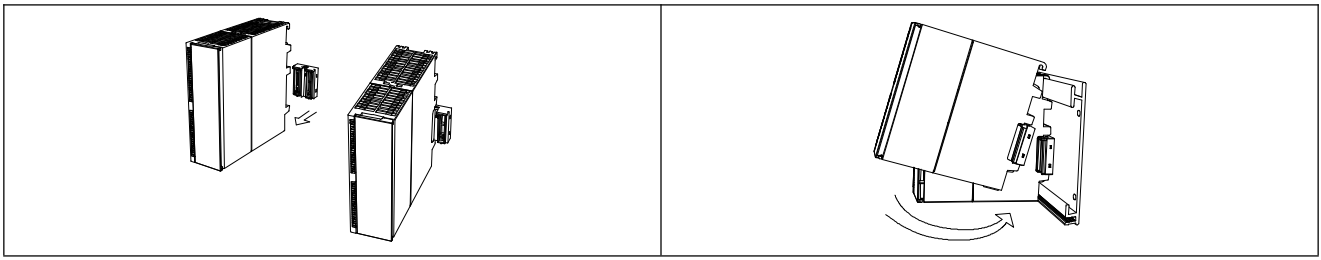

⑦ Please use screws to fix the screw hole under the module #1

⑧ Continue to install the following modules in the same way. The effect is shown in the following figure.

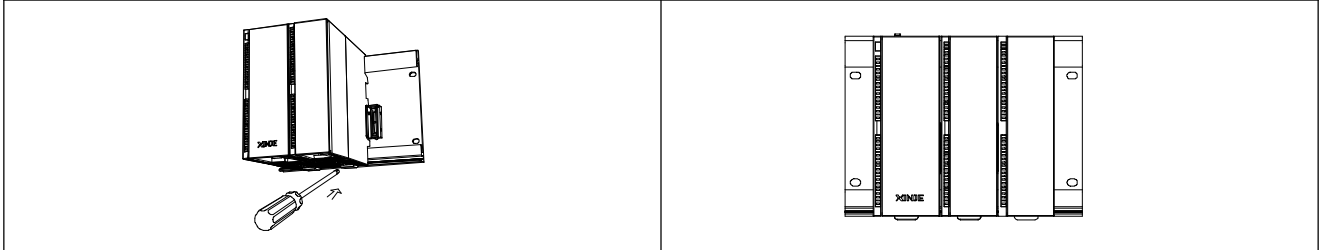

Note:

※1: If the power module XG-P75-E is selected, please install the power module to the left side of the PLC body according to the installation steps ① ~ ④.

※2: The R port on the back of the last expansion module does not need to install U-connector.

(3) XSLH series installation

Installation of basic unit and expansion module, rail installation is optional.

- ◆ Use DIN46277 rail to install

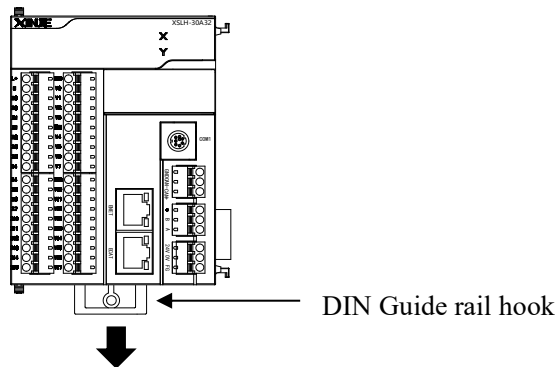

The unit and expansion module are installed on DIN46277 guide rail (35mm wide). To remove, just pull down the assembly hook of the DIN rail and remove the product by translating it to the right.

(4) XSA330 installation

The XSA330 is installed with using matching guide rails.

Please use the rail R99- 15 DIN to install.

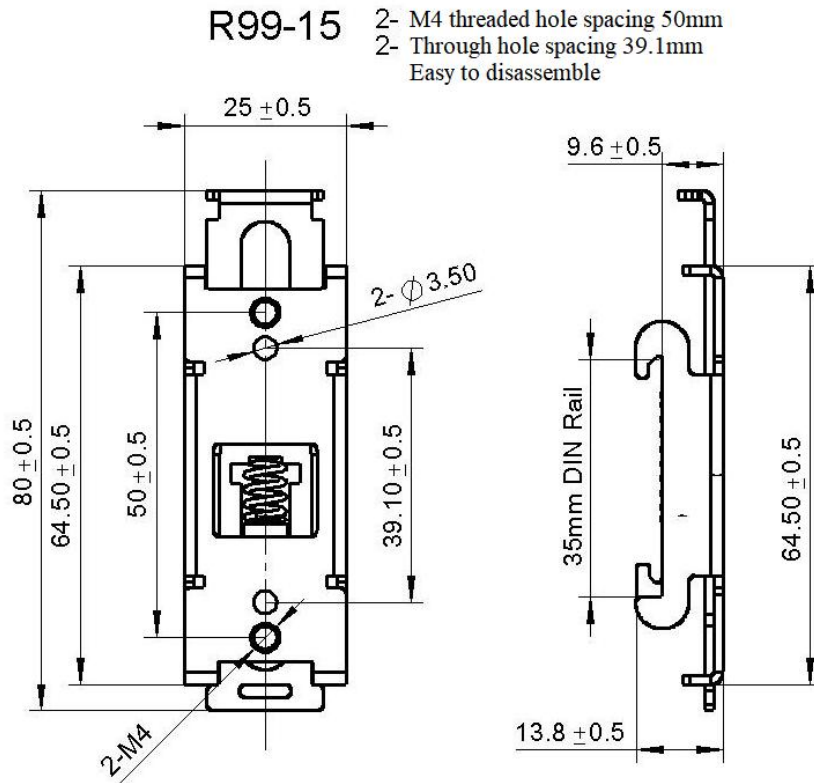

First, install the black rail buckle on the bottom of the controller with two screws, then fix the end with spring on the top of the DIN rail, and then gently push against the side of the spring to fix the entire buckle on the rail. To remove, gently push one end of the spring to remove the product.

3-4-4. Installation environment

Please install the product under the environmental conditions specified in chapter 2-1-1.

4. Power supply specification

4-1. Power supply specification

The power specification of XSDH series PLC only supports AC power type.

The power specification of XS3 series PLC only supports DC power type.

The power specification of XSLH series PLC only supports DC power type.

The power specification of XSA330, XSA500 IPC only supports DC power type.

(1) AC power type

Item	Content
Rated voltage	AC100V~240V
Voltage allowable range	AC90V~265V
Rated frequency	50/60Hz
Allowable instantaneous power off time	Interrupt time ≤ 0.5 AC cycle, space ≥ 1 s
Impact current	Max below 40A 5ms/AC100V max below 60A 5ms/AC200V
Maximum power consumption	30W
Power supply for sensor	24VDC $\pm 10\%$ max 400mA

Note:

※1: Please use more than 2mm² wires for power cables to prevent voltage drop.

※2: Even in case of power failure within 10ms, the programmable controller can still continue to work. When the power is cut off for a long time or the abnormal voltage drops, the programmable controller will stop working and the output will also be in off state. When the power supply is restored, the programmable controller will automatically start running.

※3: The grounding terminal FG of basic unit and expansion module can be connected with each other and reliably grounded (the third kind of grounding).

(2) DC power type

XSDH, XS3, XSLH series PLC power supply specification:

Item	Content
Rated voltage	DC24V
Voltage allowable range	DC21.6V~26.4V
Input current (basic unit)	120mA DC24V
Allowable instantaneous power off time	10ms DC24V
Impact current	10A DC26.4V
Maximum power consumption	12W

XSA series power supply specification:

Item	Content
Rated voltage	DC24V
Input current	2.5A DC24V
Maximum power consumption	60W

Note: terminal is empty, please do not use it as external wiring or relay terminal.

4-2. AC Power supply DC input

(1) XSDH, XSLH, XS3 series wiring

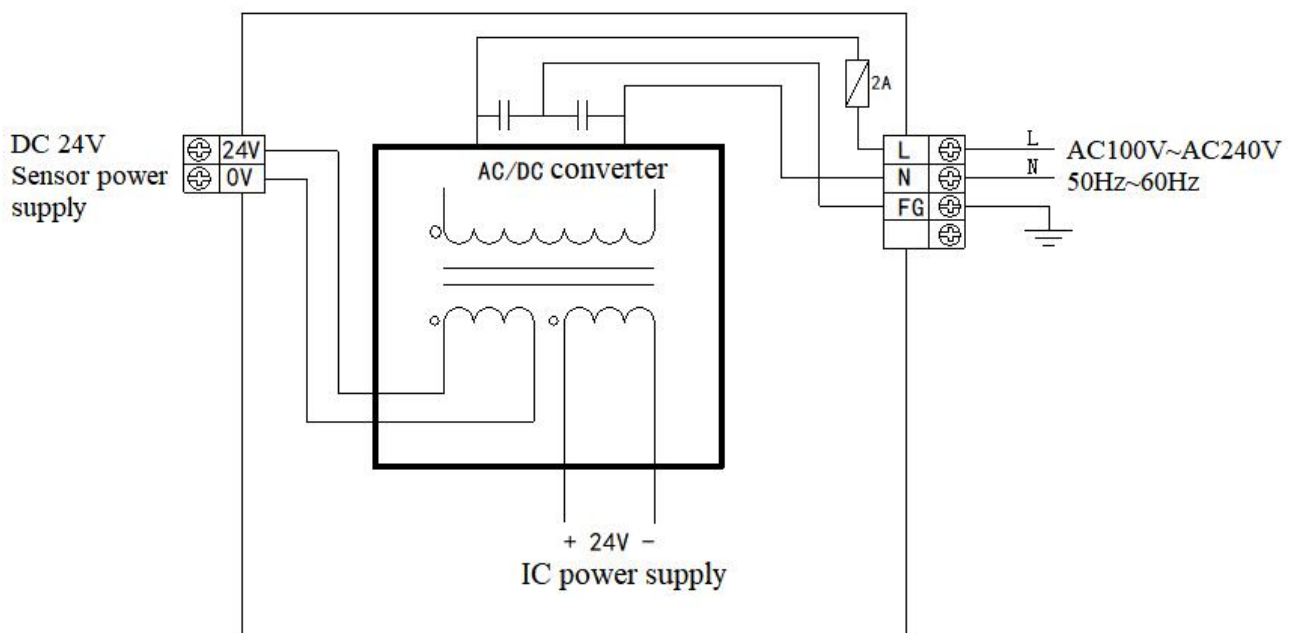

Note:

- ※1: Connect the power supply between terminals L and N.
- ※2: The 24V and 0V terminals can be used as power supply for sensors, with 200mA/DC24V at 10/16 points and 400mA/DC24V at 24 points and above. Additionally, this terminal cannot be powered by external power sources.
- ※3: terminal is vacant terminal. Please do not connect it externally or use it as a relay terminal.
- ※4: It is recommended to connect the terminals of the basic unit and expansion unit to each other.

(2) XSA power supply wiring

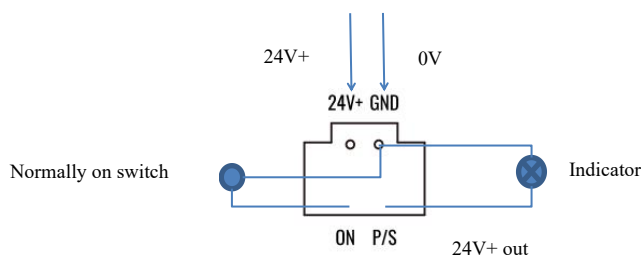

- ① 24V+ and GND: IPC power supply.
- ② ON and GND: Turn ON/OFF IPC
- ③ P/S and GND: Serial indicator light displays the operating status.

5. Input specification and wiring

5-1. Input specification

5-1-1. XSDH series input specification

XSDH series PLC supports NPN or PNP input mode. The specific specifications and wiring mode are described below:

(1) NPN input

Item	Content
Input signal voltage	DC24V±10%
Input signal current	7mA/DC24V
Input ON current	Above 4.5mA
Input OFF current	Below 1.5mA
Input response time	About 10ms
Input signal mode	Contact input or NPN open collector transistor
Circuit insulation	Optoelectronic coupling insulation
Input action display	LED is on when input is on

NPN wiring example:

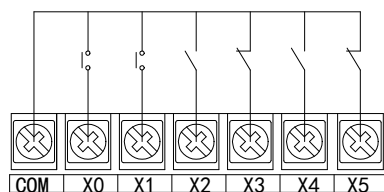

Switch button wiring diagram example

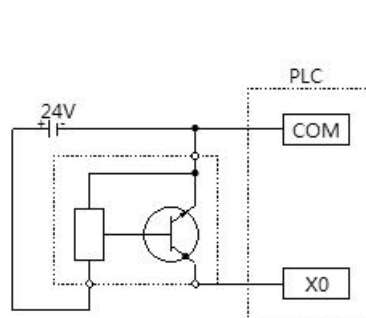

3-wire (NPN type) proximity switch wiring diagram

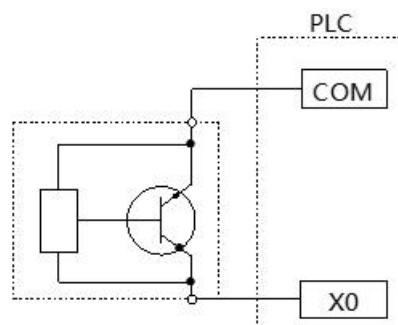

2-wire (NPN type) proximity switch wiring diagram

(2) PNP input

Item	Content
Input signal voltage	DC24V±10%
Input signal current	7mA/DC24V
Input ON current	Above 4.5mA
Input OFF current	Below 1.5mA
Input response time	About 10ms
Input signal mode	Contact input or PNP open collector transistor
Circuit insulation	Optoelectronic coupling insulation
Input action display	LED is on when input is on

PNP wiring example:

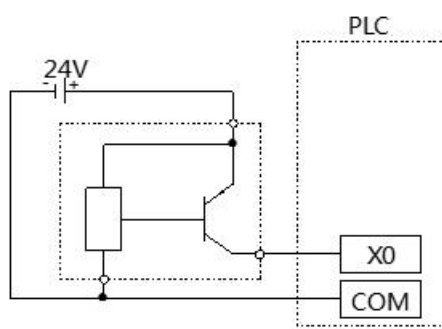
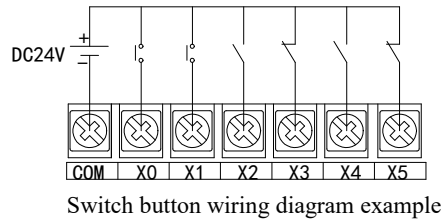

3-wire (PNP type) proximity switch wiring diagram

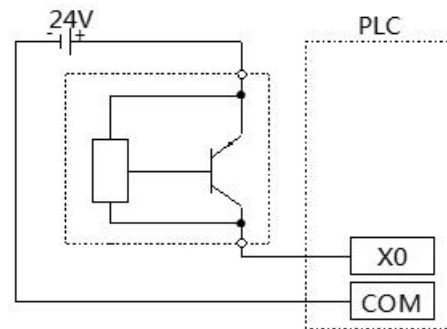

2-wire (PNP type) proximity switch wiring diagram

5-1-2. XS3 series input specification

XS3 series PLC supports NPN and differential input modes. The specific specifications and wiring mode are described below:

(1) NPN mode

Item	Content
Input signal voltage	DC24V±10%
Input signal current	7mA/DC24V
Input ON current	Above 4.5mA
Input OFF current	Below 1.5mA
Input response time	About 10ms
Input signal mode	Contact input or NPN open collector transistor
Circuit insulation	Optoelectronic coupling insulation
Input action display	LED lights when input is ON

NPN wiring example:

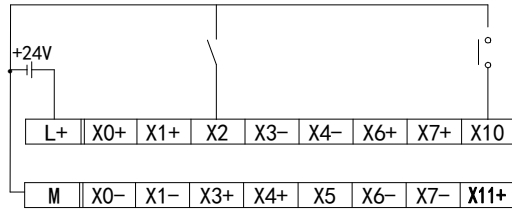

switch button wiring diagram example

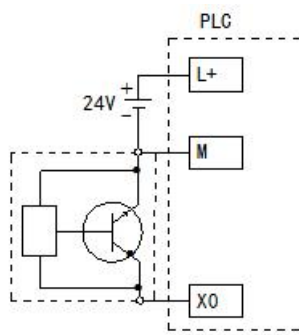

2-wire (NO or NC) proximity switch wiring diagram

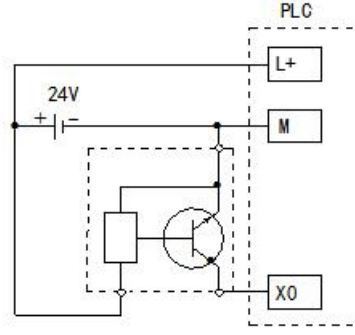

3-wire (NPN type) proximity switch wiring diagram

(2) Differential mode

Item	Content
Input signal voltage	DC5V±10%
Input signal current	12mA/DC5V
Input ON current	Above 4.5mA
Input OFF current	Below 1.5mA
Input response features	Max 200KHz
Input signal mode	Differential input
Circuit insulation	Optoelectronic coupling insulation
Input action display	LED lights when input is ON

Differential input wiring example:

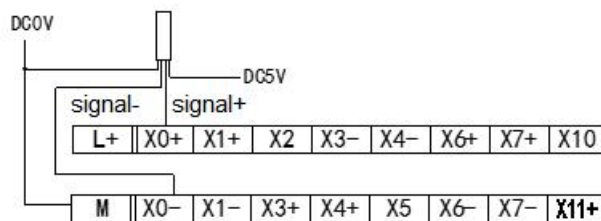

Differential wiring diagram example

5-1-3. XSLH series input specification

XSLH-24A8 and XSLH-24A16 support two input modes: NPN and PNP, while XSLH-30A32 supports two input modes: NPN and differential. The specific specifications and wiring mode are described below:

(1) NPN mode

Item	XSLH-24A8, XSLH-24A16	XSLH-30A32
NPN input points	12 points (X0~X13)	12 points (X2, X5~X15)
High speed counter input	8 points (X0, X1, X3, X4, X6, X7, X11, X12) single phase 80KHz, AB phase 50KHz	4 points (X6, X7, X11, X12), single phase 80KHz, AB phase 50KHz
Input signal voltage	DC24V±10%	
Input signal current	7mA/DC24V	
Input ON current	Above 4.5mA	
Input OFF current	Below 1.5mA	
Input response time	About 10ms	
Input signal mode	Contact input or NPN open collector transistor	
Circuit insulation	Optoelectronic coupling insulation	
Input action display	LED lights when input is ON	

NPN wiring example:

- ◆ XSLH-24A8, XSLH-24A16

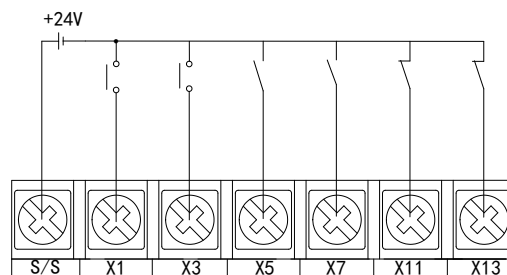

switch button wiring diagram

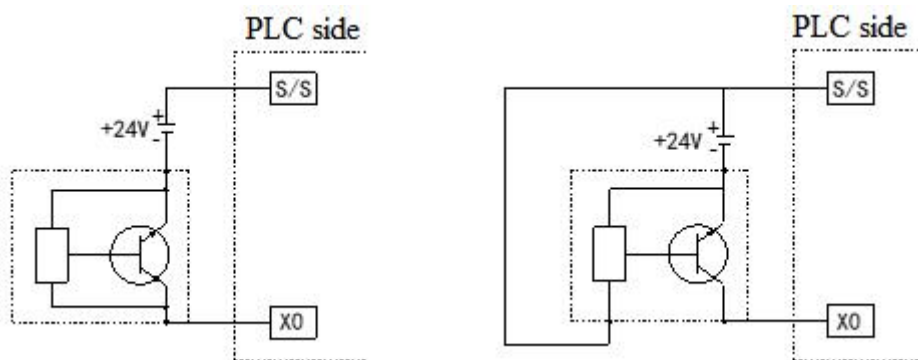

2-wire (NO or NC) proximity switch

3-wire (NPN) proximity switch

◆ XSLH-30A32

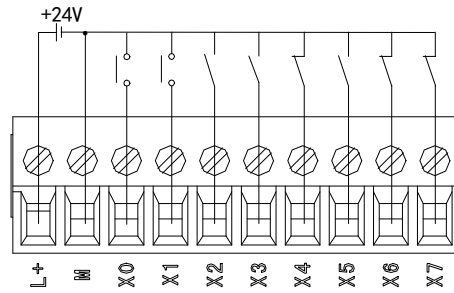

switch button wiring diagram

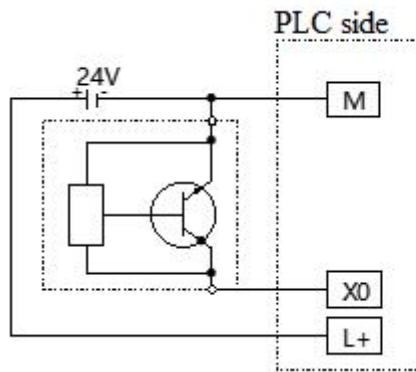

2-wire (NO or NC) proximity switch

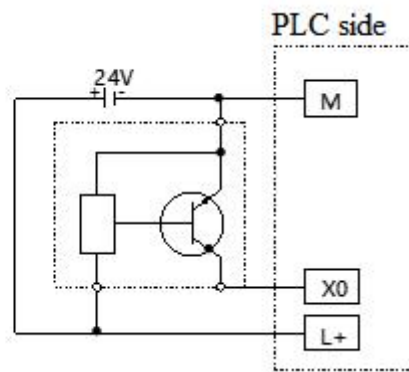

3-wire (NPN) proximity switch

(2) PNP mode

Item	XSLH-24A8, XSLH-24A16
PNP input	12 points (X0~ X13)
Input signal voltage	DC24V±10%
Input signal current	7mA/DC24V
Input ON current	Above 4.5mA
Input OFF current	Below 1.5mA
Input response time	About 10ms
Input signal mode	Contact input or PNP open collector transistor
Circuit insulation	Optoelectronic coupling insulation
Input action display	LED lights when input is ON

PNP wiring example:

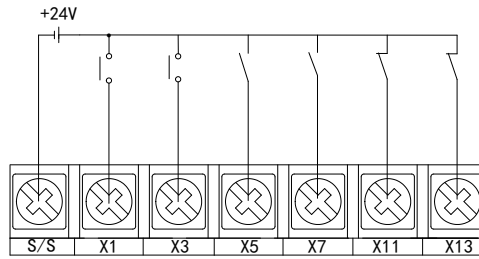

switch button wiring diagram

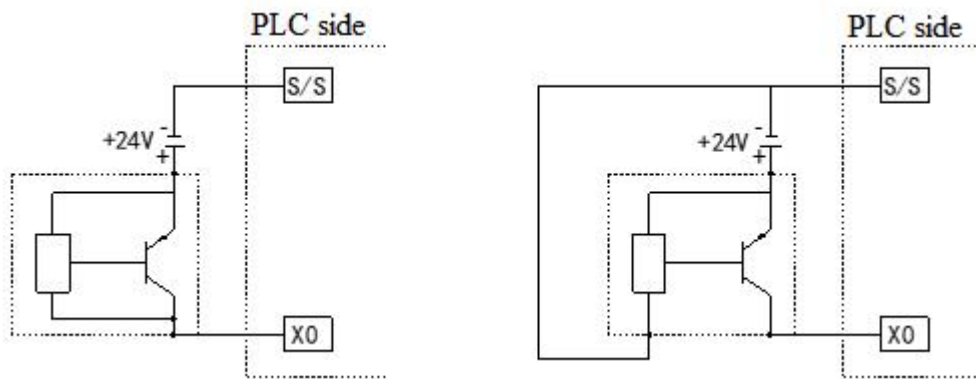

2-wire (NO or NC) proximity switch

3-wire (PNP) proximity switch

(3) Differential mode

Item	XSLH-30A32
Differential input	4 points (X0, X1, X3, X4)
Input signal	5V differential signal
Input max frequency	1MHz
Circuit insulation	Optoelectronic coupling insulation
Input action display	LED lights when input is ON

Differential input wiring example:

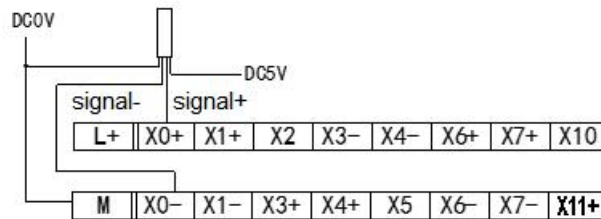

Differential wiring diagram example

5-1-4. XSA series input specification

The XSA330 series supports NPN and PNP input modes, while the XSA500 series supports bipolar input mode. Below are the specifications and wiring methods.

5-1-4-1. XSA330 input specification

(1) Input specification

Item	Content
Input signal voltage	DC24V±10%
Input signal current	7mA/DC24V
Input ON current	Above 4.5mA
Input OFF current	Below 1.5mA
Input response time	Low speed 0.1ms, high speed 5μs
Input signal mode	Bidirectional optocoupler
Circuit insulation	Optoelectronic coupling insulation

(2) Wiring example

- NPN wiring example:

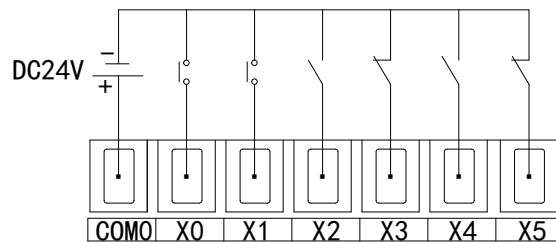

Switch button wiring diagram example

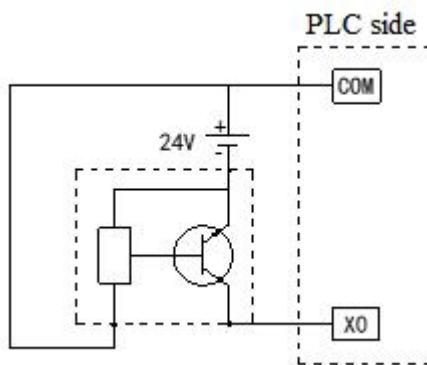

3-wire (NPN type) proximity switch wiring diagram

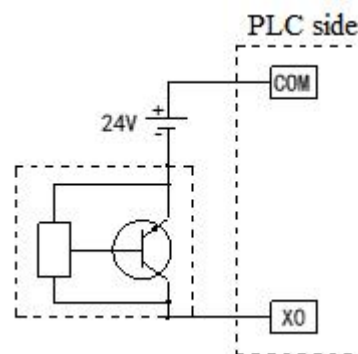

2-wire (NPN type) proximity switch wiring diagram

- PNP wiring example:

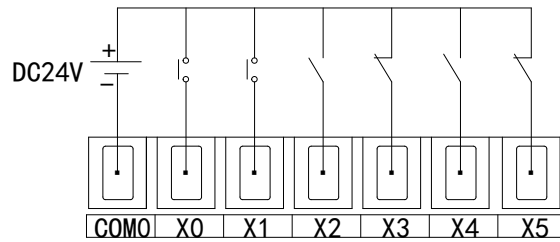

Switch button wiring diagram example

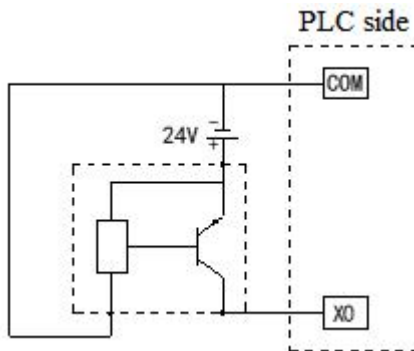

2-wire (NO or NC) proximity switch wiring diagram

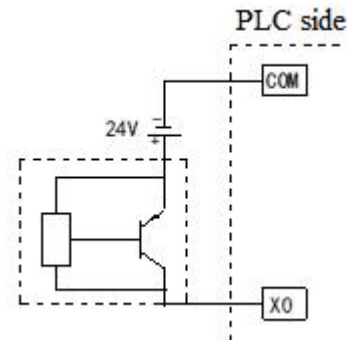

3-wire (PNP type) proximity switch wiring diagram

5-1-4-2. XSA500 input specification

(1) Input specification

Item	Content
Input signal voltage	DC24V±10%
Input signal current	7mA/DC24V
Input ON current	Above 4.5mA
Input OFF current	Below 1.5mA
Input response time	Low speed 0.1ms, high speed 5us
Input signal mode	Bidirectional optocoupler
Circuit insulation	Optoelectronic coupling insulation

(2) Wiring example

- NPN wiring example

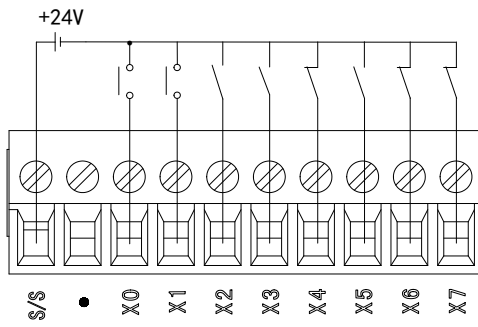

Switch button wiring diagram example

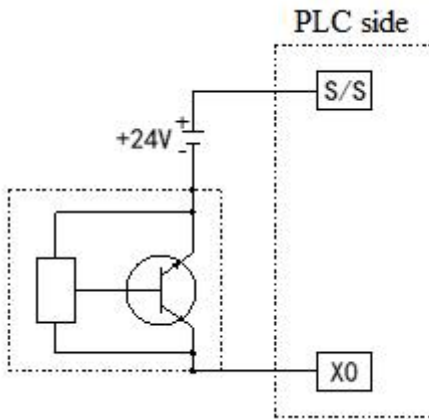

3-wire (NPN type) proximity switch wiring diagram

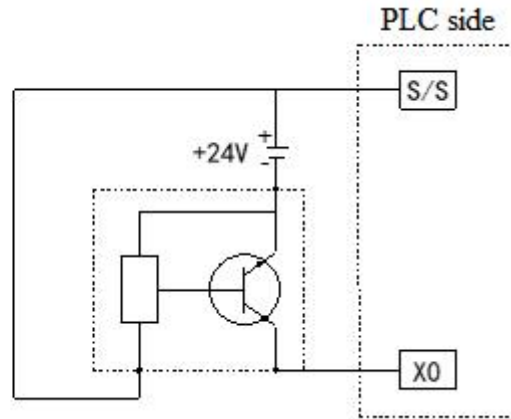

2-wire (NPN type) proximity switch wiring diagram

- PNP wiring example

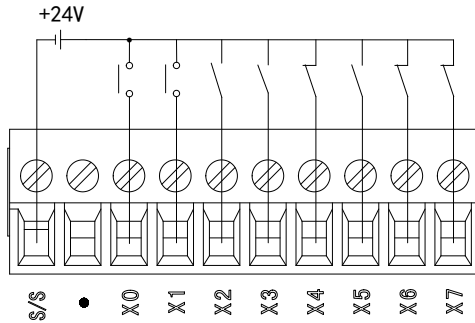

Switch button wiring diagram example

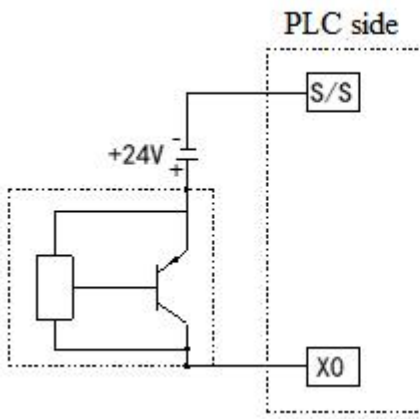

2-wire (PNP type) proximity switch wiring diagram

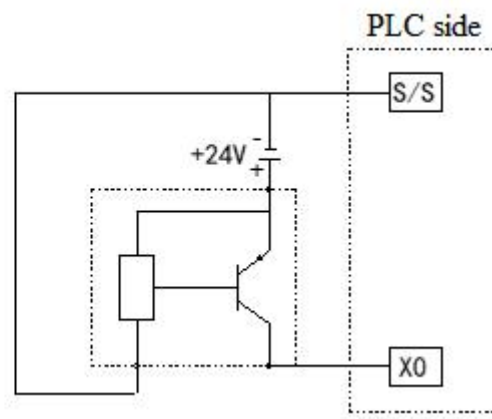

3-wire (PNP type) proximity switch wiring diagram

5-2. DC input signal

(1) NPN mode

■ Input terminal

Input terminal and **M** terminal is connected by no voltage contactor or NPN open collector transistor, then the input is ON, the corresponding LED lights.

■ Input circuit

The input primary circuit and secondary circuit are insulated by optical coupler, and the secondary circuit is equipped with C-R filter. This is set to prevent misoperation caused by input contact vibration or input line mixed noise.

Due to the above reasons, for input ON→OFF, OFF→ON changes, the response time lags about 6ms inside the PLC. Digital filter is built in the input terminal.

■ Input sensitivity

The input current of the programmable controller is DC24V 7mA, but for the sake of reliable operation, when it needs to be on, it is more than 4.5mA, and when it is off, it is less than 1.5mA.

(2) Differential mode (XSDH, XSLH-24 series not support)

■ Input terminal

Input terminal and **M** terminal is connected by DC5V contactor, then the input is ON, the corresponding LED lights.

■ Input circuit

The input primary circuit and secondary circuit are insulated by optical coupler, and the secondary circuit is equipped with C-R filter. This is set to prevent misoperation caused by input contact vibration or input line mixed noise.

Due to the above reasons, for input ON→OFF, OFF→ON changes, the response time lags about 10ms inside the PLC. Digital filter is built in the input terminal.

■ Input sensitivity

The input current of the programmable controller is DC5V 12mA, but for the sake of reliable operation, when it needs to be on, it is more than 4.5mA, and when it is off, it is less than 1.5mA.

5-3. High speed count input

XSDH/XS3/XSLH/XSA series PLC has a high-speed counting function independent of the scanning cycle of the programmable controller. By selecting different counters, it can measure the high-speed input signals such as the measurement sensor and rotary encoder. The maximum measurement frequency of XS3 can reach 200kHz.

The high-speed counting input of XS3 series PLC can only receive differential signal (DIFF) and cannot receive open collector signal. Please be sure to select the encoder of differential signal (DIFF).

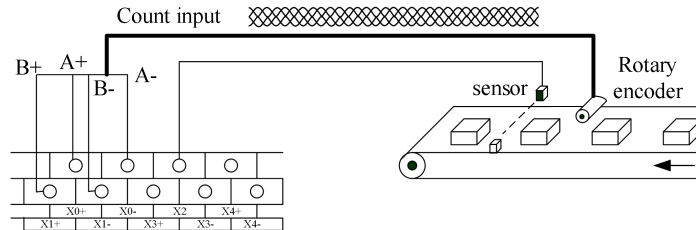

When the counting frequency is higher than 25Hz, please select the high-speed counter.

5-3-1. Count mode

XSDH/XS3/XSLH/XSA series high-speed counting function has two counting modes, namely, incremental mode and AB phase mode.

(1) Incremental mode

In this mode, the input pulse signal is counted, and the count value increases with the rising edge of each pulse signal.

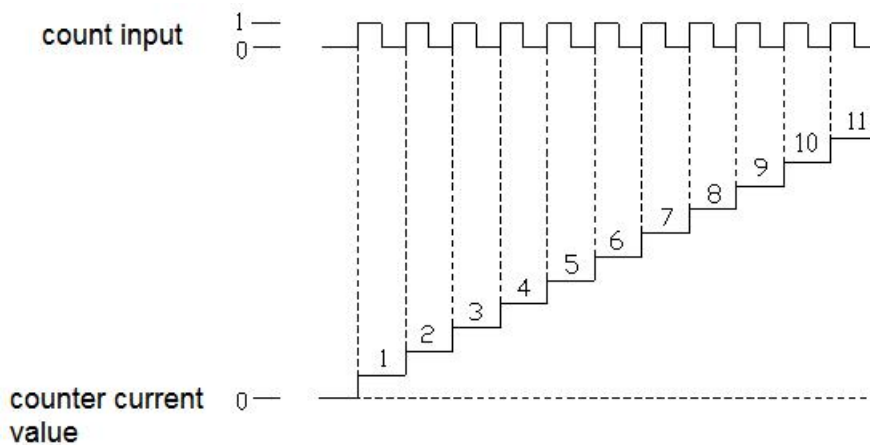

(2) AB phase mode

In this mode, the high-speed count value is incremented or decremented according to two differential signals (phase A and phase B), and the counting mode is quadruple frequency mode.

Quadruple mode

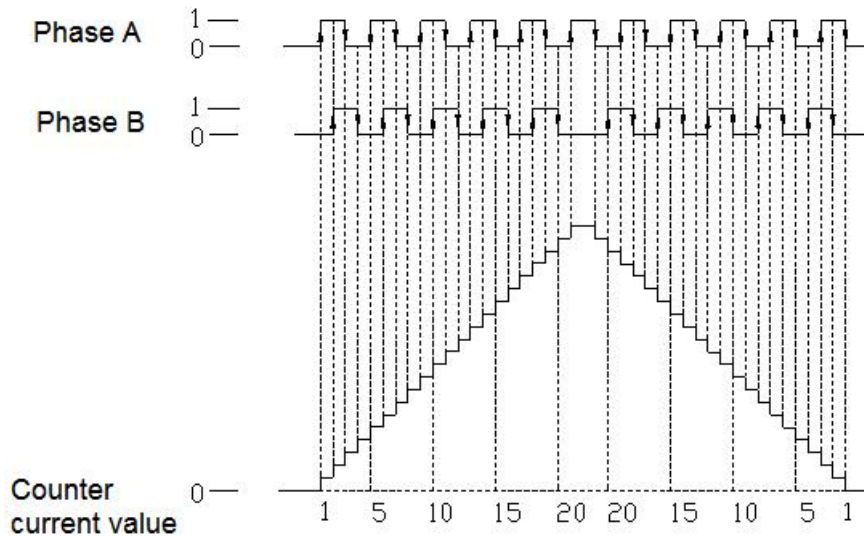

5-3-2. High-speed counter range

The counting range of high-speed counter is: $-2147483648 \sim +2147483647$. When the count value exceeds this range, overflow or underflow occurs.

The overflow means that the count value jumps from $+2147483647$ to -2147483648 and continues counting. When underflow occurs, the count value jumps from -2147483648 to $+2147483647$ and continues counting.

5-3-3. High-speed counter input wiring

For the counting pulse input terminal wiring, it is slightly different according to the programmable controller type and counter model. Several typical input terminal wiring methods are shown in the following figure:

(1) Incremental mode

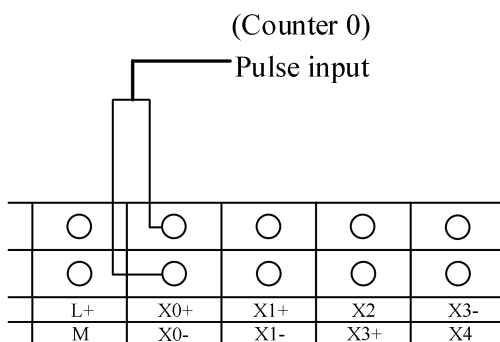

(2) AB phase mode

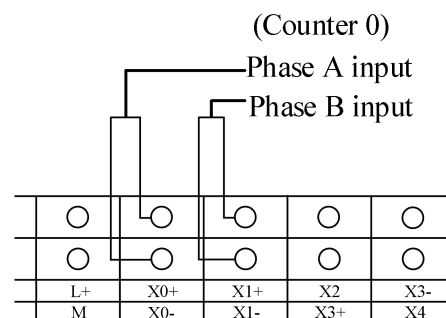

5-3-4. Input terminal assignment

(1) XSDH/XS3/XSLH series PLC high speed counter channels:

PLC model		High speed counter channel	
		Incremental mode	AB phase mode
XSDH	60 points	4	4
XS3	26 points	4	4
XSLH	24 points	4	4
	30 points	4	4

(2) High speed counter input terminal definition:

U	A	B
Counting pulse input	Phase A input	Phase B input

Under normal circumstances, the maximum frequency of XSDH and XS3 series high-speed counting terminals can reach 200KHz in single-phase mode, 100kHz in AB phase mode for XSDH and 200kHz for XS3. XSLH can up to 1MHz in differential mode, 80KHz in single phase mode and 50KHz in AB phase mode. When the X input terminal is not used as a high-speed input port, it can be used as a common input terminal. The specific port allocation and functions are shown in the following table:

XS3-26T4								
CounterID	Single phase incremental mode				AB PHASE MODE			
	0	1	2	3	0	1	2	3
Max frequency	200k	200k	200k	200k	200k	200k	200k	200k
X0+	U+				A+			
X0-	U-				A-			
X1+					B+			
X1-					B-			
X2								
X3+		U+				A+		
X3-		U-				A-		
X4+						B+		
X4-						B-		
X5								
X6+			U+				A+	
X6-			U-				A-	
X7+							B+	
X7-							B-	
X10								
X11+				U+				A+
X11-				U-				A-
X12+								B+
X12-								B-
X13								

XSDH-60A32-E								
CounterID	Single phase incremental mode				AB PHASE MODE			
	0	1	2	3	0	1	2	3
Max frequency	200k	200k	200k	200k	100k	100k	100k	100k
X0	U				A			
X1					B			
X2								
X3		U				A		
X4						B		
X5								
X6			U				A	
X7							B	
X10								
X11				U				A
X12								B
X13								

XSLH-24A8, XSLH-24A16								
CounterID	Single phase incremental mode				AB PHASE MODE			
	0	1	2	3	0	1	2	3
Max frequency	80K	80K	80K	80K	50K	50K	50K	50K
Frequency doubling					2/4	2/4	2/4	2/4
Counter interrupt	√	√	√	√	√	√	√	√
X0	U				A			
X1					B			
X2								
X3		U				A		
X4						B		
X5								
X6			U				A	
X7							B	
X10								
X11				U				A
X12								B

XSLH-30A32								
	Single phase incremental mode				AB PHASE MODE			
CounterID	0	1	2	3	0	1	2	3
Max frequency	1M	1M	80k	80k	1M	1M	50k	50k
X0+	U+				A+			
X0-	U-				A-			
X1+					B+			
X1-					B-			
X2								
X3+		U+				A+		
X3-		U-				A-		
X4+						B+		
X4-						B-		
X5								
X6			U				A	
X7							B	
X10								
X11				U				A
X12								B
X13								
X14								
X15								

XSA series								
	Single phase incremental mode				AB PHASE MODE			
CounterID	0	1	2	3	0	1	2	3
Max frequency	1M	1M	200k	200k	1M	1M	100k	100k
A0+	U+				A+			
A0-	U-				A-			
B0+					B+			
B0-					B-			
Z0+								
Z0-						A+		
A1+		U+				A-		
A1-		U-				B+		
B1+						B-		
B1-								
Z1+								
Z1-								
X0			U				A	
X1							B	
X2								
X3				U				

XSA series								
	Single phase incremental mode				AB PHASE MODE			
X4								A
X5								B
X6								
X7								

6. Output specification and wiring method

6-1. Output specification

(1) Normal transistor output

External power supply		Below DC5~30V
Circuit insulation		Optocoupler insulation
Action indicator		LED light
Max load	Resistive load	0.3A
	inductive load	7.2W/DC24V
	Light load	1.5W/DC24V
Min load		DC5V 2mA
Open circuit leakage current		< 0.1mA
Response time	OFF→ON	< 0.2ms
	ON→OFF	< 0.2ms

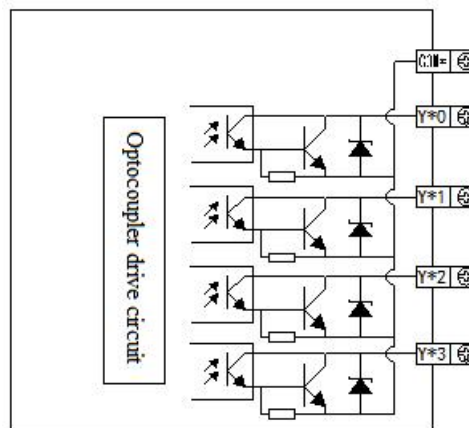

Note:

The PLC is generally equipped with a plug-in spring connector to facilitate wiring when it leaves the factory. The connector requires that the stripped length of the wire shall be at least 1.5cm. When wiring, press the yellow spring switch with a small screw drive, insert the wire into the corresponding socket, and release the spring switch.

(2) Transistor high speed pulse output

Model	XSLH-24A8, XSLH-24A16
High speed pulse output terminals	Y0~Y3
External power supply	Below DC5~30V
Action display	LED light
Max current	50mA
Max output frequency	100kHz

[Note]: When using the high-speed pulse output function, the PLC can output 100KHz~200KHz pulses, but it cannot guarantee that all servos operate normally. Please connect a resistor of about 500 ohms between the output end and the 24V power supply. The high-speed pulse output terminals of PNP type and NPN type are the same.

6-2. Transistor output

(1) General transistor output

- ◆ External Power Supply
Please use DC5~30V power supply to drive the load.
- ◆ Circuit Isolation
Inside PLC, we use photoelectric couplers to isolate between internal circuits and output transistors
- ◆ Action Display
When photoelectric couplers drive, LED will be ON and the output transistors will be ON.
- ◆ Response Time
The time interval that PLC from photoelectric couplers energizing (or cutting) to transistor ON (or OFF) is below 0.2ms.
- ◆ Output current
The current it outputs is 0.3A per point. But limited by the temperature rising, every 4 points current add up to 0.5A.
- ◆ Open circuit current
Below 0.1mA.

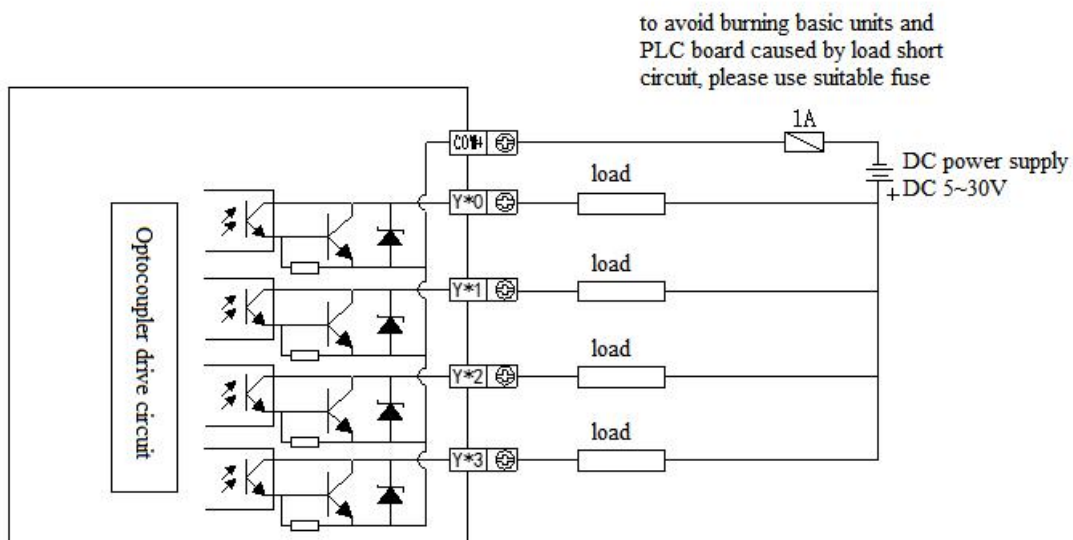

Example: the following is the wiring diagram of T-type PLC and stepper motor driver.

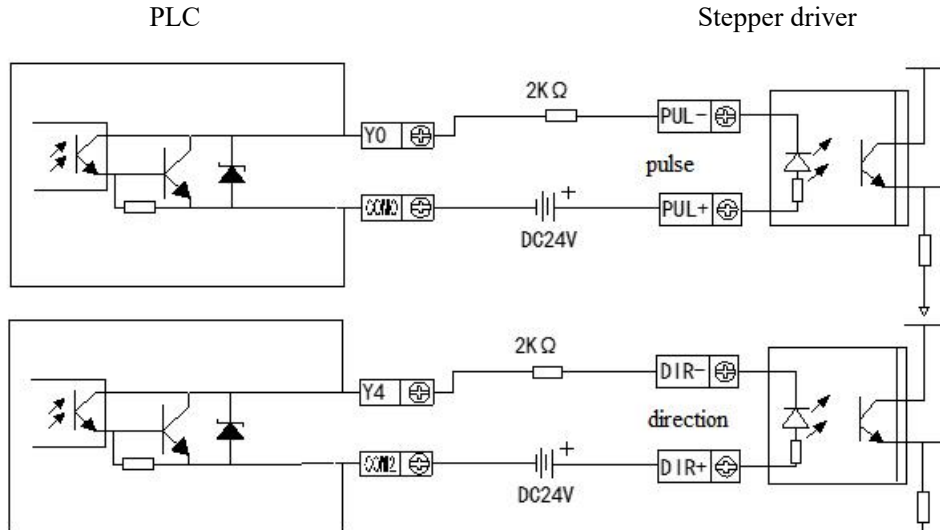

(Make sure the driver's photoelectric coupling input terminal has 8~15mA reliable current)

(2) Output circuit protection

For inductive load of DC circuit, freewheeling diode shall be added, as shown in the following figure:

- DC load

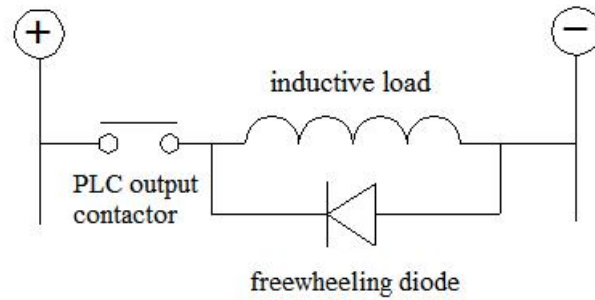

Note: freewheeling diode is 1N4007.

7. BIOS setting

7-1. BIOS explanation

BIOS is a basic input/output control program stored in Flash Memory. This program is a bridge between the motherboard and the operating system, responsible for managing the relevant parameter settings between the motherboard and the expansion card. When the controller is activated, it will be controlled by the BIOS program. First, it will execute a POST self-test, which will detect all hardware devices and confirm the synchronization of hardware parameters. When all tests are completed, it transfers control of the system to the operating system (OS). Since BIOS is the only channel between hardware and software, how to properly set the parameters in BIOS will determine whether your computer runs stably and works in the best state. Therefore, the correct setting of BIOS is a key factor for system stability, thus ensuring that the system performance can reach the best state.

CMOS Setup will store the set data in the CMOS SRAM built in the motherboard. When the power is off, the lithium battery on the motherboard continues to power the CMOS SRAM. The BIOS setup utility allows you to configure.

- (1) Hard disk drives and peripherals
- (2) Video display types and display options
- (3) Password protection
- (4) Power management function



Note

As the BIOS version of the motherboard is constantly upgraded, the BIOS description in this manual is for reference only.

We can not guarantee that the relevant contents in this manual are consistent with the information you have obtained.

7-1-1. CMOS setup

When the controller starts, the BIOS enters the power on self-test (Post) program. The self-test program is a series of diagnostic programs fixed in the BIOS. When the self-test program is completed, no errors are encountered. If you want to enter the BIOS, press DEL or ESC until you enter the BIOS interface. If this information disappears before you respond, you can shut down and restart your computer, or press<Ctrl>+<Alt>+<Delete>at the same time to restart the computer

7-1-2. Function keys and auxiliary instructions

↑ (Up button)	Move to the previous item
↓ (Down button)	Move to the next item
← (Left button)	Move to the left item
→ (Right button)	Move to the right item
ESC	Exit the present interface
Enter	To confirm
+	Change the setting state or increase the value
-	Change the setting state or decrease the value
F1	To show the help document
F2	To load the last setting value
F3	To load the optimized value
F4	Store the set value and leave the CMOS SETUP program

Auxiliary description of the main screen:

When you are in the Setup main screen, the main settings of the corresponding options are displayed below as the options move.

If you want to leave the auxiliary description window, just press the [ESC] key.

7-2. Main menu

When you enter the CMOS setup setting menu, you can see the main menu shown in at the top of the screen.

In the main menu, you can select different setting options by pressing the left and right direction keys. After selecting the submenu, detailed setting options will be displayed below.

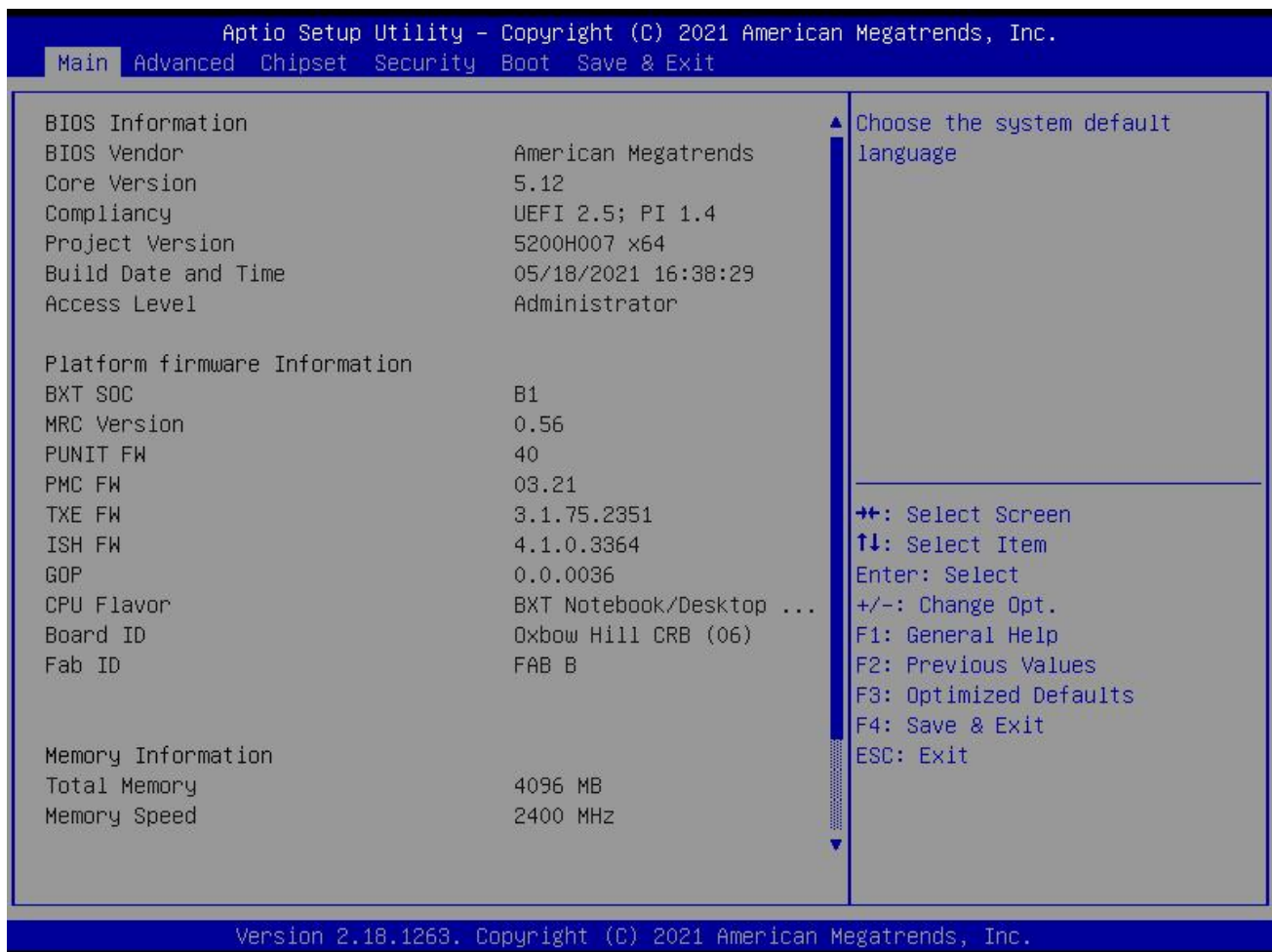

Main menu

1)Main (standard CMOS function setting)

Set the date, time, etc.

2)Advanced (Advanced BIOS function settings)

Set the special functions provided by BIOS, such as CPU, USB, PCI, network port, etc.

3)Chipset(Chipset Performance Settings)

Set device options such as North Bridge and South Bridge.

4)Security (set Administrator/User password)

5)Boot(Boot item configuration feature)

6)Save & Exit:

This option includes discarding changes, exiting without saving, and exiting without saving.

7-3. Main(Standard CMOS setting)

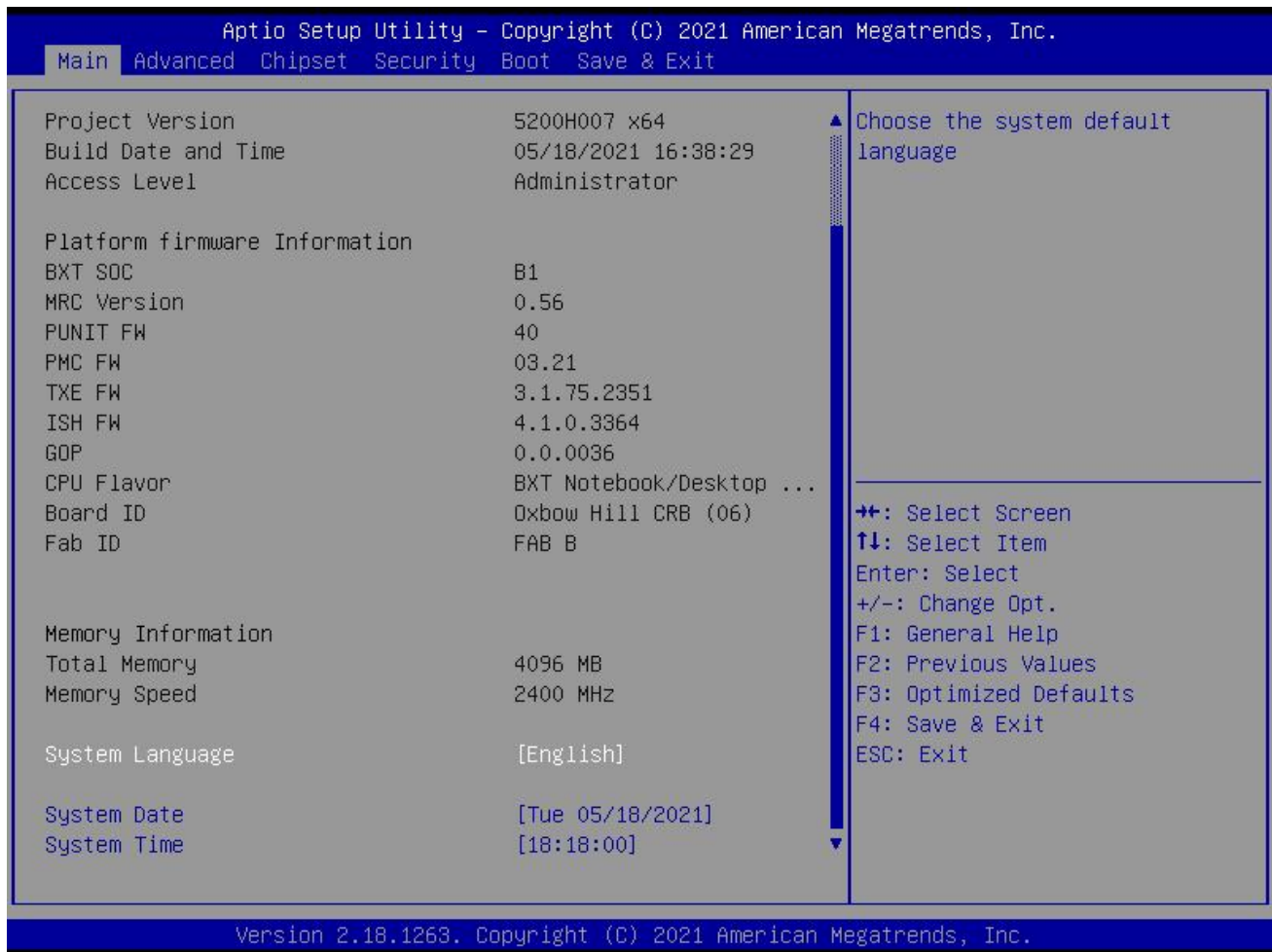

Main menu

1)System Language

Set the language

2)System Date(mm:dd:yy)

Set the date in the computer in the format of "Sunday/Month/Day/Year"

3)System Time(hh:mm:ss)

Set the time in the computer in the format of "hour/minute/second"

7-4. Advanced BIOS function

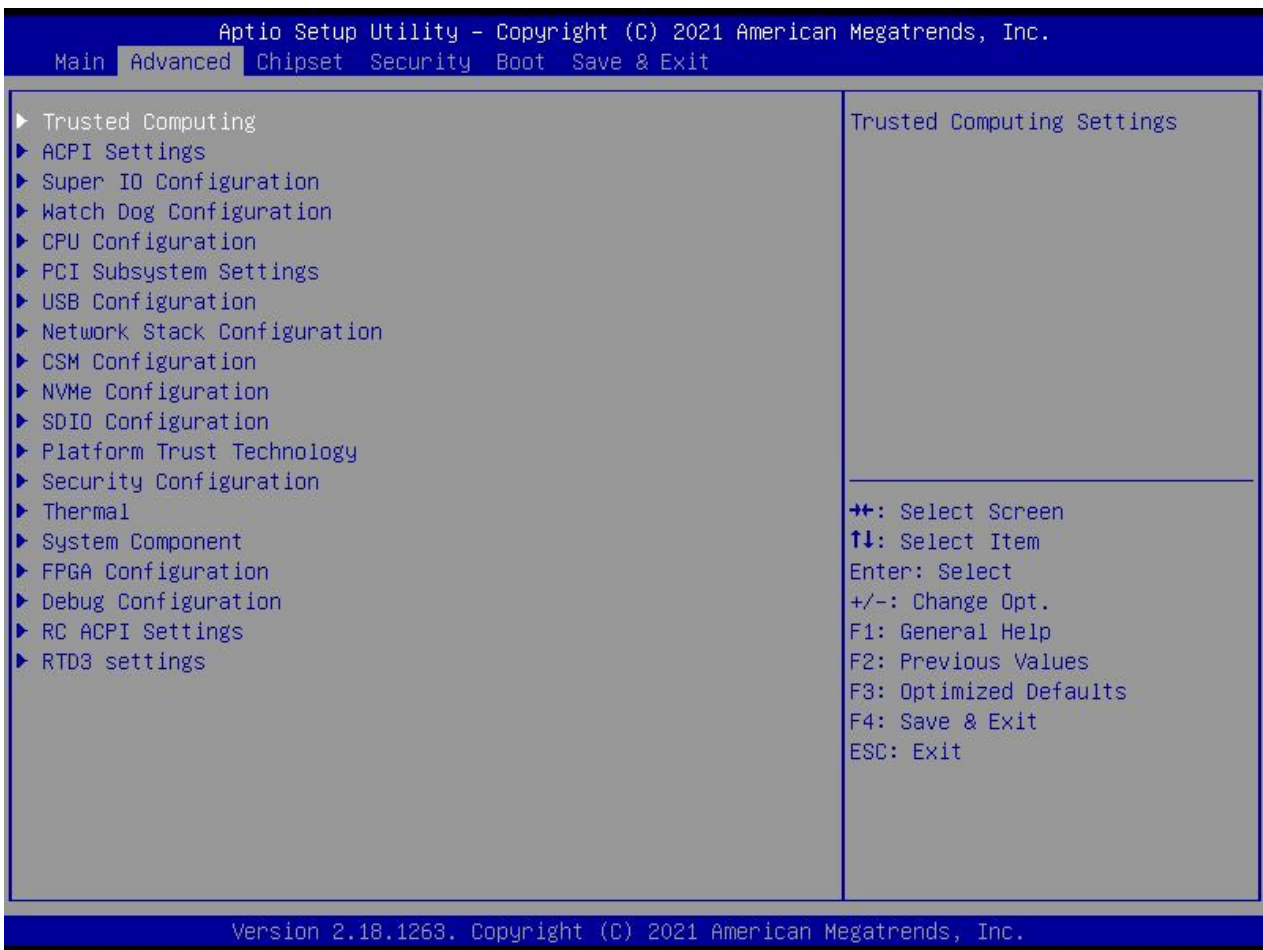

- 1) Trusted Computing:
- 2) ACPI Settings:
- 3) SMART Settings:
- 4) Super IO Configuration:
- 5) Watch Dog Configuration:
- 6) CPU Configuration:
- 7) PCI Subsystem Settings:
- 8) USB Configuration:
- 9) Network Stack Configuration:
- 10) CSM Configuration:
- 11) NVMe Configuration:
- 12) SDIO Configuration:
- 13) Platform Trust Technology:
- 14) Security Configuration:
- 15) Thermal:
- 16) System Component:

- 17) FPGA Configuration:
- 18) Debug Configuration:
- 19) RC ACPI Settings:
- 20) RTD3 Settings:

7-5. Chipset performance setting

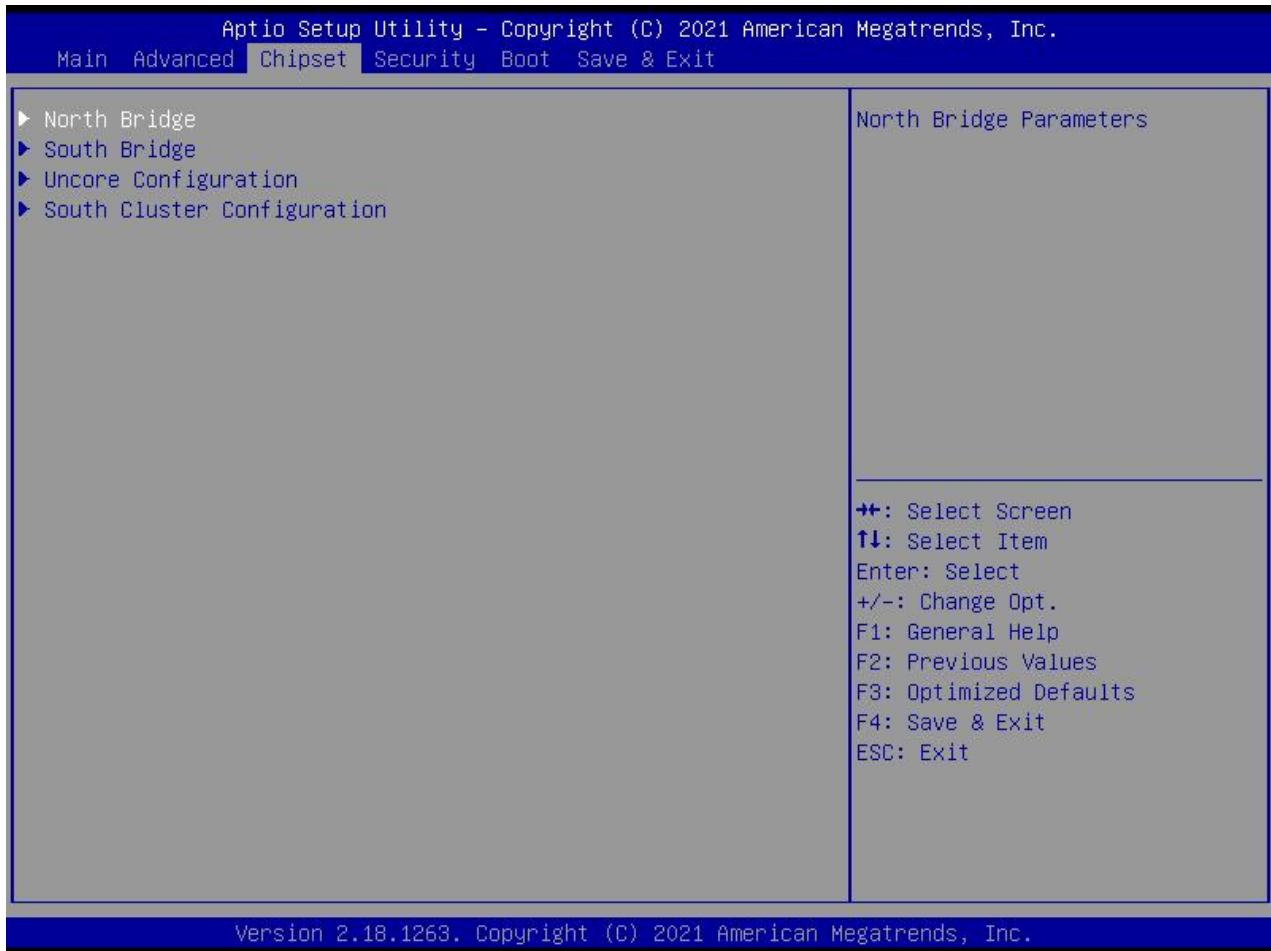

Chipset menu

- 1) North Bridge:
- 2) South Bridge:
- 3) Uncore Configuration:
- 4) South Cluster Configuration:

7-6. Security (Administrtor/User password)

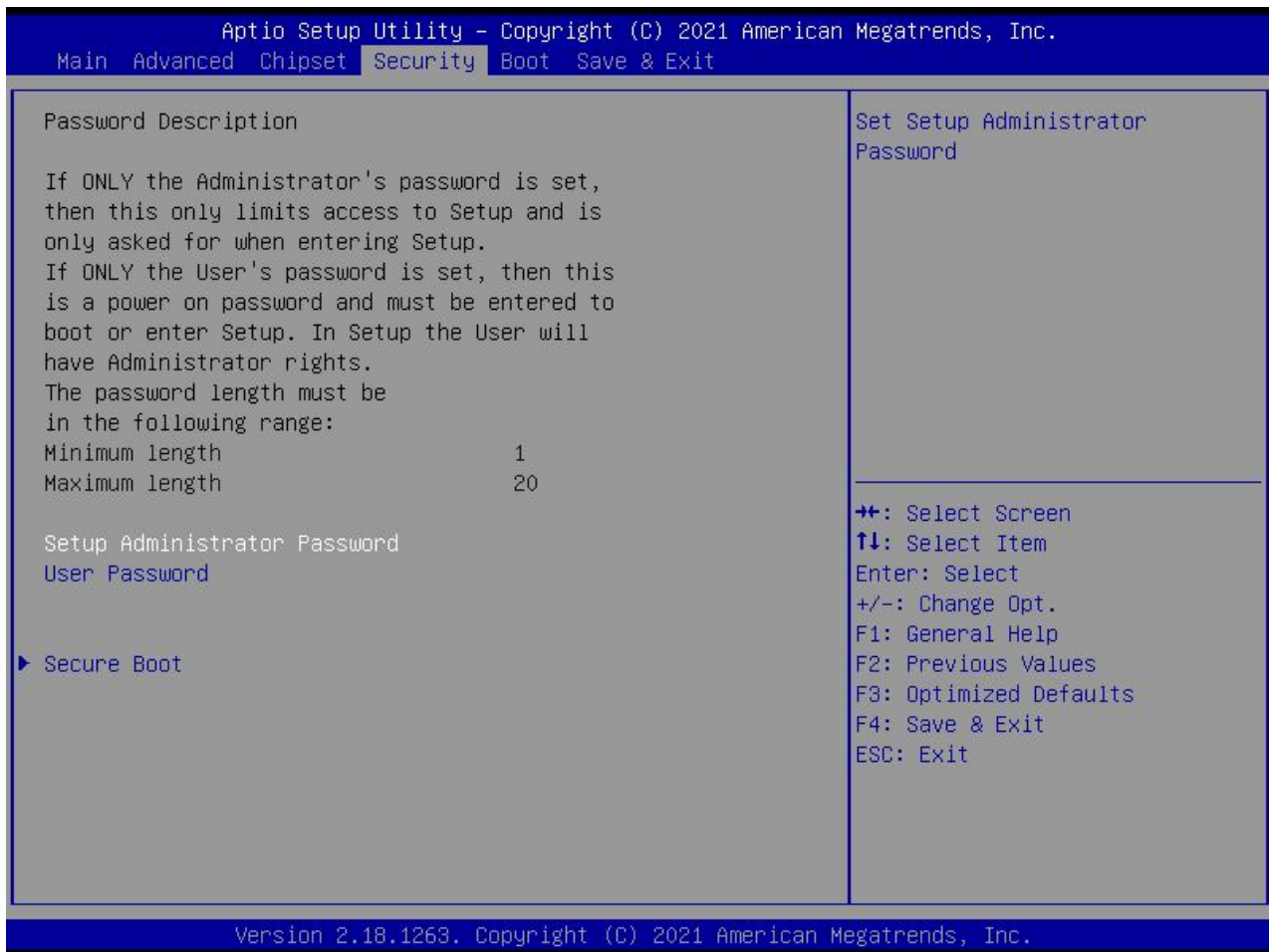

Security menu

1) Setup Administrator Password:

Set the super user password option, which has the highest permissions.

When you select this function, the following message will appear: Create New Password*****

Enter a password of up to 20 characters, and then press the <Enter> key. The BIOS requires you to enter the same password again. After entering it, the BIOS saves the set password. Once using the password function, you will be asked to enter a password each time before entering the BIOS setup program. This can prevent any unauthorized person from using your controller.

2) User Password:

Set the user password option. This password permission will be restricted, and some settings cannot be changed.

When you select this function, the following message will appear: Create New Password*****

Enter the password, up to 20 characters, and press the <Enter> key. The BIOS requires the same password to be input again. After the input is completed, the BIOS saves the set password. Once you use the password function, you will be asked to enter the password before entering the BIOS setup program.

3) Secure Boot

7-7. Boot setting

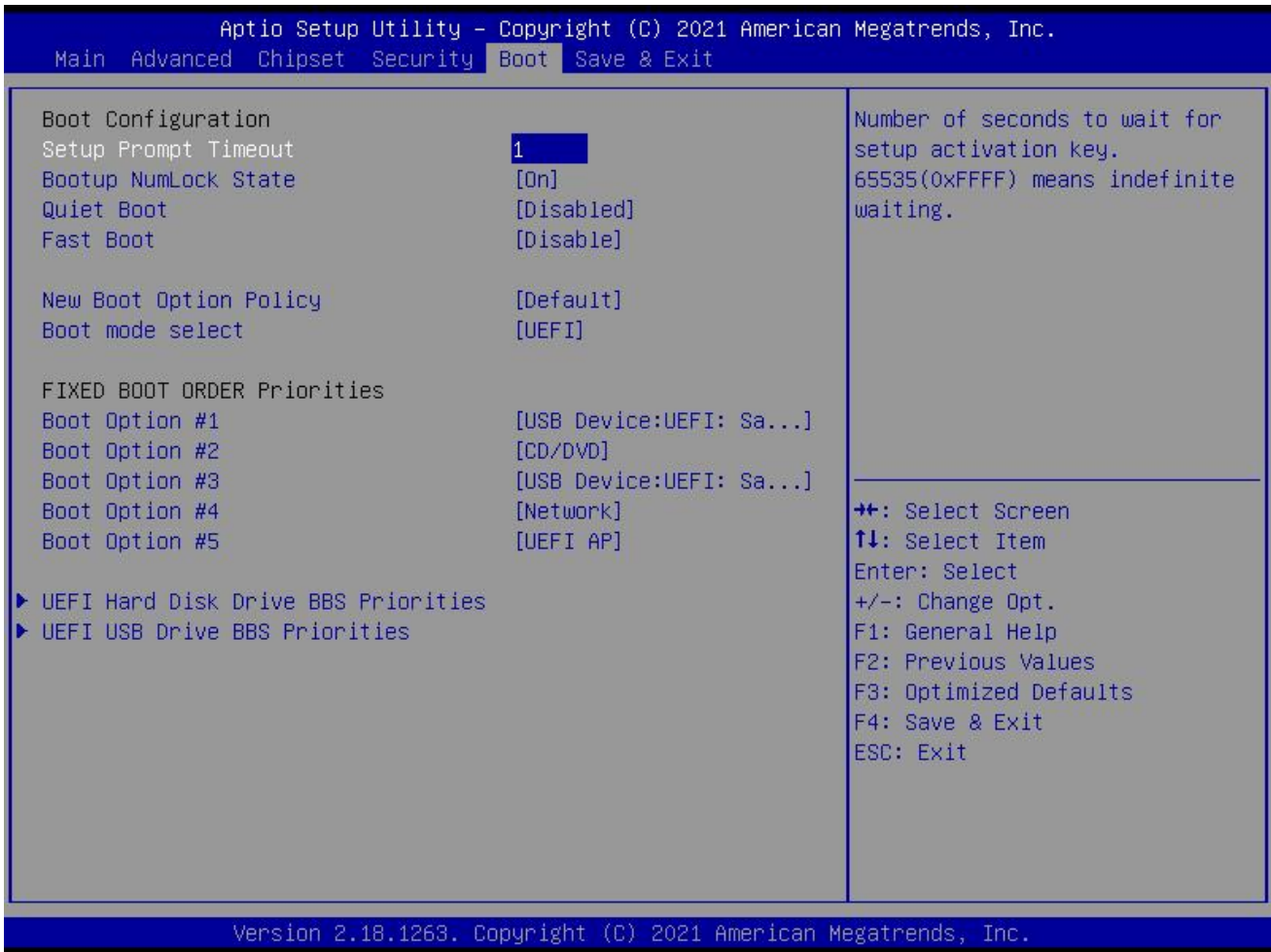

Boot menu

1) Boot Configuration:

Setup Prompt Timeout

The POST dwell time is displayed at startup. The larger the value, the longer the dwell time.

Bootup NumLock State: Num Lock key state after system startup

Setting value: [On] / [Off]. This option specifies the state of the Num Lock key on the keyboard after the controller is started.

Quiet Boot

Setting value: [Disabled] / [Enabled]. This option specifies whether to display a LOGO when the controller starts.

2) Boot Option Priorities:

Boot Option #1: First boot option. Use this option to choose which disk to start from

Fast Boot

Setting value: [Disabled] / [Enabled]

This option specifies whether to perform hardware self testing at startup.

3) New Boot Option Policy

7-8. Save & Exit

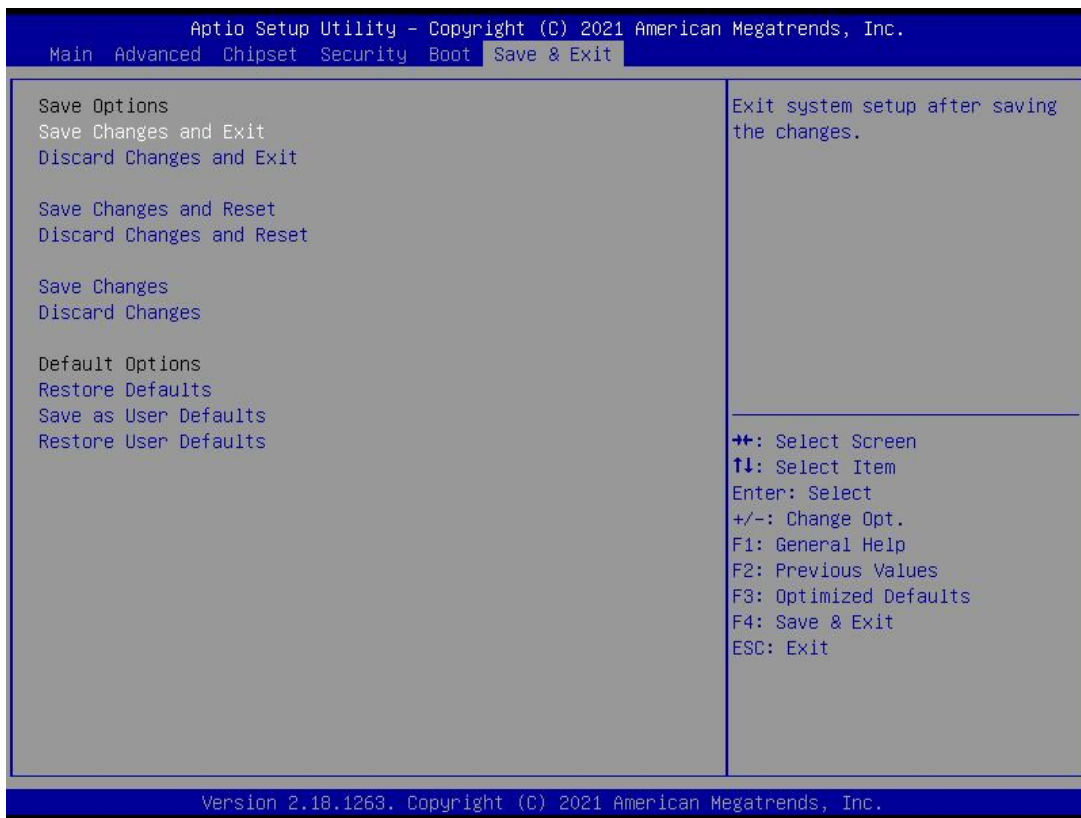

Save&Exit menu

1)Save Options

Save Changes and Reset

Discard Changes and Reset

2)Defaults Options

Restore Defaults: Load Optimal Defaults

This option in the main menu allows the user to restore all BIOS options to optimized values. The optimization default value is the default value set to optimize the performance of the motherboard. If you select YES and press Enter, you can save all the settings to CMOS SRAM and leave the BIOS setup program. If you do not want to save, select NO to return to the main menu.

Save as User Defaults

Restore as User Defaults

3)Boot Override

7-9. Set COM port mode

Select Advanced → Super IO configuration

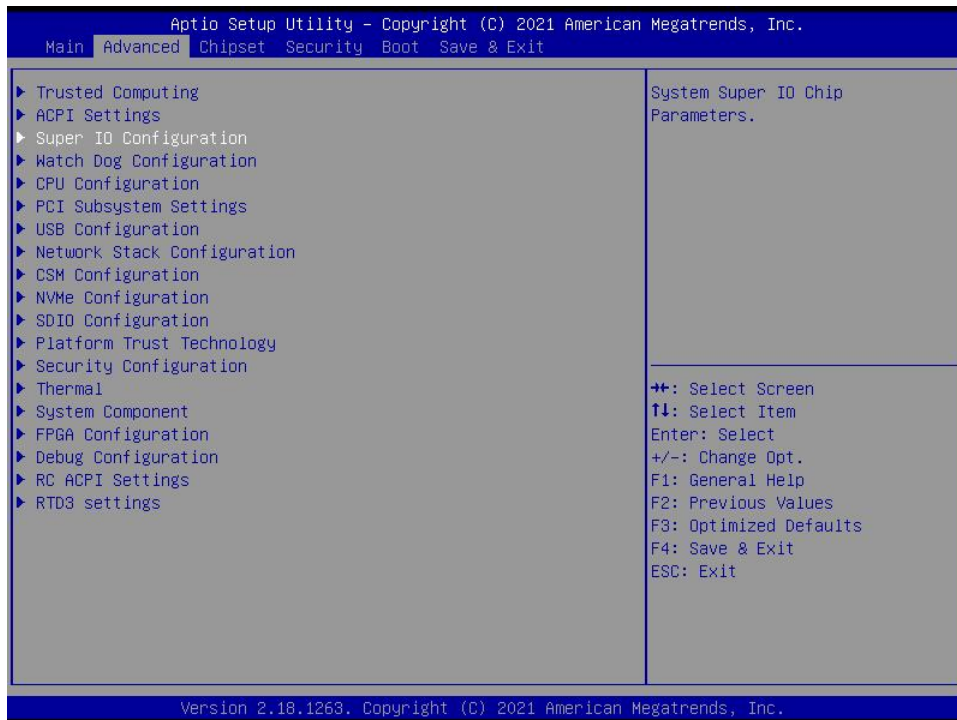

Select the COM port, enter, there is COM mode options, please select RS232, RS485.

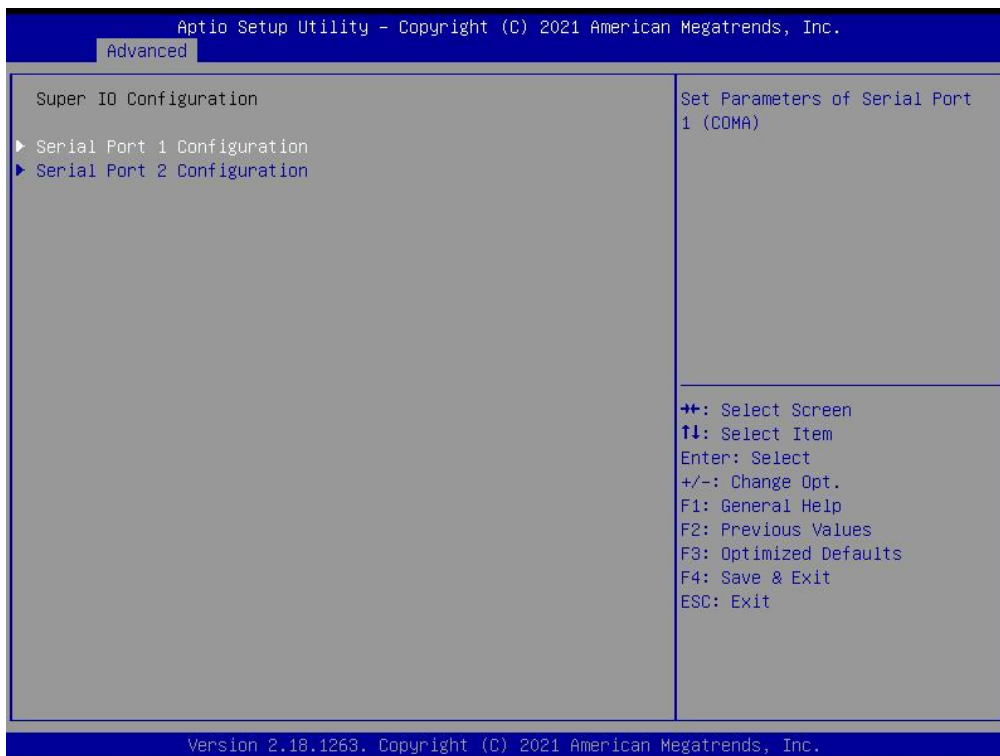

Aptio Setup Utility - Copyright (C) 2021 American Megatrends, Inc.

Advanced

Serial Port 1 Configuration	Com Mode
Serial Port [Enabled]	
Device Settings IO=3F8h; IRQ=4;	
Change Settings [Auto]	
COM Mode [RS232 Mode]	

COM Mode
RS422 Mode
RS232 Mode
RS485 Mode

++: Select Screen
↑↓: Select Item
Enter: Select
+/-: Change Opt.
F1: General Help
F2: Previous Values
F3: Optimized Defaults
F4: Save & Exit
ESC: Exit

Version 2.18.1263. Copyright (C) 2021 American Megatrends, Inc.

8.Operation, commissioning and maintenance

8-1. Operation and commissioning

(1) Product inspection

After receiving the product, please first check whether the input and output terminal blocks of the product are intact and whether there are missing parts. Generally speaking, the PLC at this time can be directly connected to the power cable for power on inspection, and the PWR and RUN indicators should be always on.

(2) Programming and downloading

After confirming that the product is in good condition, the PLC can be programmed. The programming is carried out in the personal computer. The completed program can be downloaded to PLC. The general operation steps are as follows:

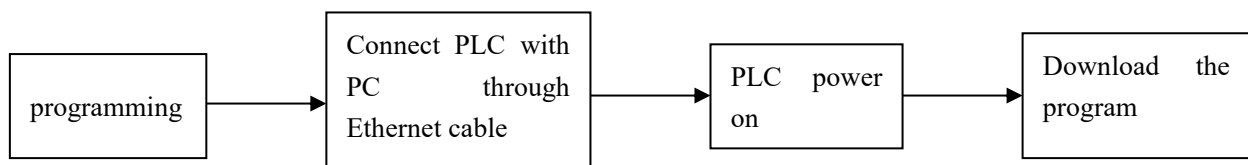

(3) Debugging

Ideally, the PLC is in normal operation, but if the program in the PLC is found to be wrong and needs to be modified, it is necessary to rewrite the program to the running PLC.

- ◆ Use Ethernet cable to connect PLC and computer
- ◆ Upload the program in the PLC
- ◆ Modify the uploaded program, and save the modified program
- ◆ Pause the operation of PLC and download the modified program to PLC
- ◆ Monitor PLC through software debugging function
- ◆ If the requirements are still not met, continue to modify the program and download it to PLC until the requirements are met.

(4) PLC indicator light

- ◆ When the PLC is in normal operation, the indicator lights PWR and RUN should always be on.
- ◆ When the indicator ERR is always on, it indicates that there is a problem with the PLC operation. Please correct the program in time.
- ◆ If the indicator PWR is not on, there is a problem with the power supply. Check the power wiring.

8-2. Routine maintenance

(1) Regular inspection of products

Although the programmable controller has certain anti-interference and strong stability, it should also form the habit of regular inspection and maintenance of the controller. The inspection items include:

- ◆ Whether the input and output terminals and power supply terminals of PLC are loose
- ◆ Whether the communication port is intact
- ◆ Whether the power indicator and input / output indicator can be lit
- ◆ Remove the accumulated dust outside the PLC to avoid dust and conductive dust falling inside the PLC
- ◆ Try to make the PLC operation and storage environment conform to the standards described in section 2-1-1 of this manual.

(2) About the battery

There are no components inside the programmable controller that can seriously shorten its service life, so it can be used all the time. However, if it is a PLC with clock function, the battery shall be replaced regularly.

- ◆ Battery model: CMOS (2-wire connection).
- ◆ The service life of the battery is generally 3-5 years.
- ◆ Please replace the battery as soon as possible after the battery power drops.
- ◆ After replacing the battery, please power on the PLC immediately, otherwise the battery may be exhausted.

(3) Discard

If you decide to discard this product, please treat it as industrial waste.

Appendix

Appendix 1. PLC function configuration list

This part is mainly for the convenience of users to check the function configuration of products of various series models. Through this table, it is easy to judge the selection of product models.

For detailed introduction of the following functions, please refer to XS series PLC user manual [motion control] and XS series PLC user manual [software].

○ user select × not support √ support

Series	Clock	USB	RS232	RS485	RJ45	CAN port	Communication		Expansion module	HSC channel		External interrupt
							Ethernet	EtherCAT		Incremental mode	AB phase	
XSDH-60A32-E	√	×	1	1	2	×	√	√	16	4	4	14
XS3-26T4	√	×	1	2	2	×	√	√	16	4	4	6
XSLH-24A8	√	×	1	1	2	×	√	√	16	4	4	10
XSLH-24A16	√	×	1	1	2	×	√	√	16	4	4	10
XSLH-30A32	√	×	1	1	2	1	√	√	16	4	4	10
XSA330	√	√	2		4	×	√	√	×	4	4	16
XSA520	√	√	2		6	×	√	√	×	4	4	16
XSA530	√	√	2		6	×	√	√	×	4	4	16
XSA550	√	√	2		6	×	√	√	×	4	4	16



- XSA series have two serial ports, both default to RS232, which can be changed to RS485 when entering BIOS.
- XSA330 has 4 Ethernet ports including 2*Ethernet and 2*EtherCAT, while XSA500 series has 6 Ethernet ports including 4*Ethernet and 2*EtherCAT.

Appendix 2. Q&A

When running or debugging PLC, users may encounter some difficult problems due to lack of experience. This part mainly aims at the problems that users are most likely to encounter, and puts forward solutions for users' reference.

Q1: Why can't PLC communicate with peripheral devices?

A1: Communication failure is generally summarized as the following problems:

- (1) Communication parameters: the communication parameter settings of PLC communication port and peripheral equipment may be inconsistent.
- (2) Communication cable: the connection may be incorrect or the contact may be poor. The user can replace the communication cable and try again.
- (3) If the above are excluded, please contact our company.

Q2: How long can the battery power in the PLC be maintained?

A2: Generally, it can last for 2-3 years.

Q3: Why can't connect to the PLC device?

A3: Failure to connect PLC is generally summarized as follows:

1. Confirmed as XS series products (XD and XG series products have been regarded as XS series in many cases).
2. Confirm that the upper computer engineering equipment is consistent with the target equipment, otherwise the equipment will not be scanned.
3. Confirm whether the IP addresses of both parties are the same network segment and can be ping. If the IP address cannot be confirmed, try to set dial 1 to ON and restart the device (the initial IP address is 192.168.6.6 after power on), and then scan and connect again. If the network segment is the same but the subnet mask is different, the device cannot be scanned, but you can directly enter the IP address to connect the device.



4. If the IP is confirmed to be correct or the device cannot be connected, it may be that the PLC program crashes (there is an endless loop in the program or the load capacity of the PLC is exceeded). At this time, set dial 2 to ON (power on does not load the user program), and scan the connected device again. If the connection can be scanned, an empty program will be downloaded at this time. After the abnormal program is erased, the dialing status will be restored. At the same time, check the abnormal program (whether there is an excessively long cycle or the task cycle time is too small).
5. If the above steps still fail to connect the device, please contact us.

Q4: XSDH and XSLH BD and ED module usage conditions.

A4: The left ED expansion of XSDH and XSLH only supports the 485 function in XD-NES-ED, provided that the latest firmware is 3.5.15.40_1.0.0_P2_20220530.

XSDH can extend one BD, but only supports XD-NE-BD, provided the latest firmware is 3.5.15.40_1.0.0_P2_20220530.

Q5: How to connect XSA330-W for the first time?

A5: XSA330-W default IP is automatically obtained, set the computer IP to automatically obtain and can scan to the device. If you want to modify the IP address of the XSA series, you need to use a DP interface to connect the monitor and modify the network port IP.

XINJE



WUXI XINJE ELECTRIC CO., LTD.

No.816, Jianzhu West Road, Binhu District,

Wuxi City, Jiangsu Province, China

214072

Tel: 400-885-0136

Fax: (510) 85111290

Email: fiona.xinje@vip.163.com

www.xinje.com